

Datasheet

Issued: July 22, 2019

File Edition: V1.0.0



Figure 1. 4CH IR Emitter with Current Detection

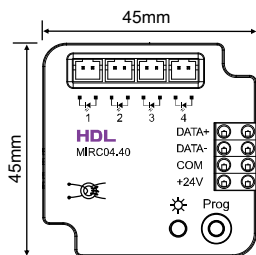

Figure 2. Dimensions - Front View

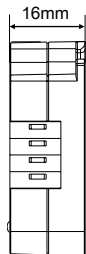

Figure 3. Dimensions - Side View

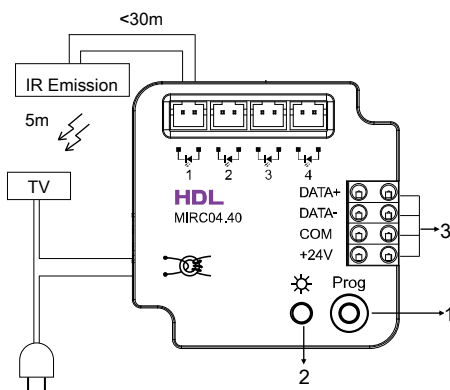

Figure 4. Wiring



Figure 5. IR emission tube

Overview

4CH IR Emitter with Current Detection (See Figure 1) can download codes saved in HDL Buspro Setup Tool, or codes uploaded via the IR Code Learner. HDL-MIRC04.40 can then transmit the IR codes to control IR devices, for example, air conditioner, TV, fan, projector, Set-Top Box, DVD, etc. It also supports current detection for devices.

Functions

- Current detection: Detect if the device is power-on or power-off.
- 4 IR emission channels drive the transmitting tube directly.
- Supports 24 devices and 100 IR codes.
- Built-in IR code library holds IR codes from common appliance manufactures.
- Codes that are not presented in the IR library can be uploaded via the IR learner.
- Sequence function, to call the sequence by universal switch, the UV switch number is 201-208.
- Supports up to 99 UV switches.
- Supports online update via HDL Buspro Setup Tool.
- Supports easy programming.

Important Notes

- Buspro cable - CAT5E or dedicated HDL Buspro cable
- Buspro connection - Series connection (hand-in-hand recommended)
- Installation - 86*86 wall box installation or fixed with screws
- IR code sending - Equipped with infrared emission tube, the emission tube has positive and negative pole, to be installed near the IR device.
- Current detection - The device to be tested is connected to the IR Emitter, and the working current of the device cannot exceed 2A.
- IR codes 1-4 can only be configured for air conditioners.

Product Information

Dimensions - See Figure 2 - 3

Wiring - See Figure 4

1. Programming button

Keep pressing the button for two seconds, the LED will keep on red, then the device address can be modified via the HDL Buspro Setup Tool.

2. LED indicator: The LED will flash in red, which indicates the module is working properly.

3. HDL Buspro: from top to bottom, DATA+, DATA-, COM, 24V DC

Note: The IR emitter is capable of sending an IR beam from the distance up to 5 meters. The standard emission tube is 1.5 meters. An additional cable up to 30 meters can be used in conjunction with the IR emitter.

Note: Take connection with TV as an example (See Figure 4). Connect the power supply cable to the current detection port in series. When the TV is turned on or off, the system will detect the status. And the system will read the current when turn on or turn off the TV. Use the average current of the two values and write it down in HDL Buspro Setup Tool, "The standby current threshold", after setting, the system can detect the power status of TV, then emit correct IR codes.

IR emission tube - See Figure 5

Installation - See Figure 6 - 7

Secure the module to the wall box or the desired position with screws.

Safety Precautions



- The installation and commissioning of the device must be carried out by HDL or the organization designated by HDL. For planning and construction of electric installations, the relevant guidelines, regulations and standards of the respective country are to be considered.
- HDL does not take responsibility for all the consequences caused by installation and wire connection that are not in accordance with this document.
- Please do not privately disassemble the device or change components, otherwise it may cause mechanical failure, electric shock, fire or body injury.
- Please resort to our customer service department or designated agencies for maintenance service. The warranty is not applicable for the product fault caused by private disassembly.

Package Contents

HDL-MIRC04.40 *1 / Buspro connector*1 / IR emission tube (1.5m)*4 / Datasheet*1

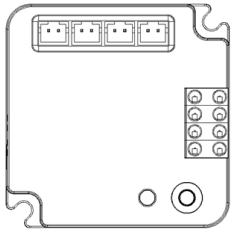

Figure 6

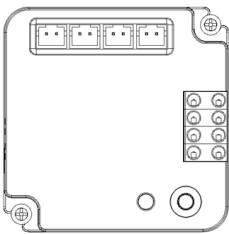

Figure 7

Figure 6 - 7. Installation

Technical Data

Basic Parameters

Working voltage	12~30V DC
Working current	30mA/24V DC
Sending carrier wave frequency	38kHz
IR control distance	5m

External Environment

Working temperature	-5°C~45°C
Working relative humidity	≤90%
Storage temperature	-20°C~60°C
Storage relative humidity	≤93%

Specifications

Dimensions	45mm×45mm×16mm
Net weight	58g
Housing material	Flame retardant ABS
Installation	86×86 wall box, Screw fix installation (See Figure 6 - 7)
Protection rating (Compliant with EN 60529)	IP20

Name and Content of Hazardous Substances in Products

Components	Hazardous substances					
	Lead (Pb)	Mercury (Hg)	Cadmium (Cd)	Chromium VI (Cr (VI))	Poly-brominated biphenyls (PBB)	Poly-brominated diphenyl ethers (PBDE)
Plastic	o	o	o	o	o	o
Hardware	o	o	o	o	-	-
Screw	o	o	o	×	-	-
Solder	×	o	o	o	-	-
PCB	×	o	o	o	o	o
IC	o	o	o	o	×	×

The symbol “-” indicates that the hazardous substance is not contained.

The symbol “o” indicates that the content of the hazardous substances in all the homogeneous materials of the component is below the limit requirement specified in the Standard IEC62321-2015.

The symbol “×” indicates that the content of the hazardous substance in at least one of the homogeneous materials of the part exceeds the limit requirement specified in the Standard IEC62321-2015.

HDL Buspro Cable Guide

HDL Buspro	HDL Buspro Cable	CAT5/CAT5E
DATA+	Yellow	Blue/Green
DATA-	White	Blue white/Green white
COM	Black	Brown white/Orange white
24V DC	Red	Brown/Orange

Technical support

E-mail: hdltickets@hdlautomation.com
 Website: <https://www.hdlautomation.com>

©Copyright by HDL Automation Co., Ltd. All rights reserved.
 Specifications subject to change without notice.