

Overview

Tile/1 Port Coax Cable TV Wall Plate (BBTV) (See Figure 1) can be used to transmit TV signal.

Product Name	Components	Model No.
Tile/1 Port Coax Cable TV Wall Plate (BBTV)	Panel	HDL-MP1-W-BBTV/TILE.48
	Frame	HDL- MP1-EC/TILE.48

Datasheet

Issued: Nov. 21, 2019

Edition: V1.0.1

Functions

- TV signal transmission

Important Notes

- The panel should be installed in wall box.
- Please ensure correct wiring.

Product Information

Dimensions - See Figure 2 - 3

Installation - See Figure 4

- Step 1. Install the wall box in the wall.
- Step 2. Secure the power interface into the wall box with screws.
- Step 3. Install the panel cover on the power interface.
- Step 4. Mount the frame around the socket.

Horizontal installation - See Figure 5

Vertical installation - See Figure 6



Figure 1. Tile/1 Port Coax Cable TV Wall Plate (BBTV)

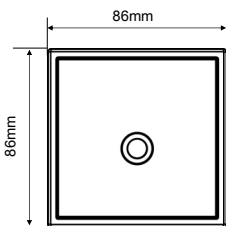

Figure 2. Dimensions-Front view

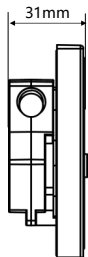

Figure 3. Dimensions-Side view

Safety Precautions

- The device should be wall box mounted. HDL does not take responsibility for all the consequences caused by installation and wire connection that are not in accordance with this document.
- Please do not privately disassemble the device or replace parts, otherwise it may cause mechanical failure, electric shock, fire or body injury.
- Please resort to our customer service department or designated agencies for maintenance service. The warranty is not applicable for the product fault caused by private disassembly.

Package Contents

Panel*1 / Screw(M4*28mm)*2 / Screw(M4*50mm)*2 / Datasheet*1

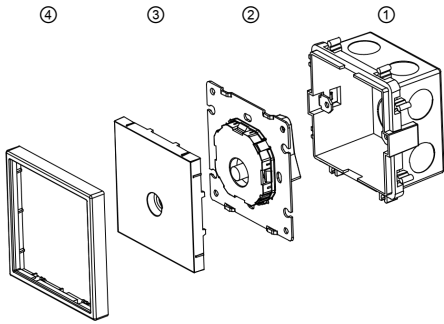

Figure 4. Installation



Figure 5. Horizontal installation



Figure 6. Vertical installation

Notes: Metal panels can be installed either horizontally or vertically. Plastic panels can be only installed horizontally.

Product Name	Frame Types	Gang	Dimensions
2/3/4-gang frames	Metal	2 gang	176*90*10.5(mm)
		3 gang	262*90*10.5(mm)
		4 gang	348*90*10.5(mm)
	Plastic	2 gang	172*86*10.5(mm)
		3 gang	258*86*10.5(mm)
		4 gang	344*86*10.5(mm)

Technical Data

Specifications

Dimensions	86×86×31(mm) (With plastic frame) 90×90×31(mm) (With metal frame)
Net weight	112g (With plastic frame)
Housing material	Flame retardant PC
Installation	Wall box (See Figure 4)

Name and Content of Hazardous Substances in Products

Components	Hazardous substances					
	Lead (Pb)	Mercury (Hg)	Cadmium (Cd)	Chromium VI (Cr (VI))	Poly-brominated biphenyls (PBB)	Poly-brominated diphenyl ethers (PBDE)
Plastic	o	o	o	o	o	o
Hardware	o	o	o	o	-	-
Screw	o	o	o	x	-	-
Solder	x	o	o	o	-	-
PCB	x	o	o	o	o	o
IC	o	o	o	o	x	x

The symbol "-" indicates that the hazardous substance is not contained.

The symbol "o" indicates that the content of the hazardous substances in all the homogeneous materials of the component is below the limit requirement specified in the Standard IEC62321-2015.

The symbol "x" indicates that the content of the hazardous substance in at least one of the homogeneous materials of the part exceeds the limit requirement specified in the Standard IEC62321-2015.

Technical support

E-mail: hdtickets@hdlautomation.com

Website: <https://www.hdlautomation.com>

©Copyright by HDL Automation Co., Ltd. All rights reserved.
Specifications subject to change without notice.