

FEATURES

- 5 different configurable blocks: shutter channels (up to 10), individual outputs (up to 20) and 2-pipe fan coil control (up to 5)
- Possibility of controlling blinds/shutters with 2 or 3 dry contacts
- Outputs suitable for capacitive loads, maximum 140 µF
- Manual output operation with push button and LED status indicator
- Supports KNX Data Secure
- 30 logic functions
- 2 Master light controls
- Output timing
- Total data saving on KNX bus failure
- Integrated KNX BCU (TP1-256)
- Dimensions 68 x 90 x 175 mm (10 DIN units)
- DIN rail mounting according to IEC 60715 TH35, with fixing clamp
- Possibility of connecting different phases in adjacent outputs
- Conformity with the CE, RCM directives (marks on the right side)

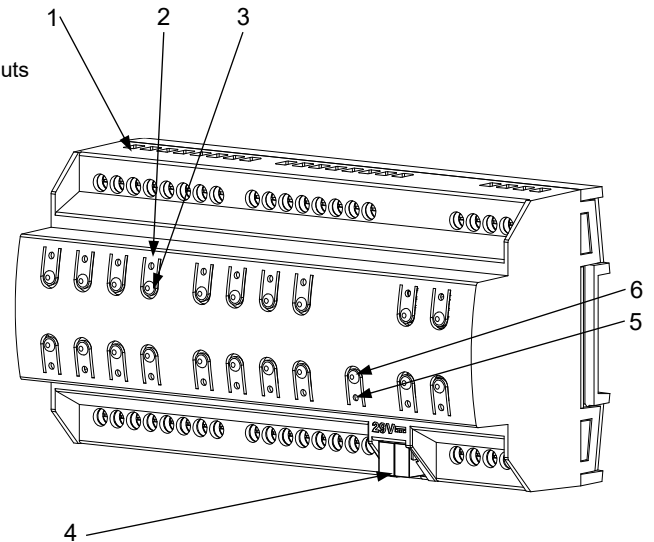

Figure 1: MAXinBOX 20

1. Outputs	2. Output status LED	3. Output control button
4. KNX connector	5. Programming/Test LED	6. Programming/Test button

Programming/Test button: short press to set programming mode. If this button is held while plugging the device into the KNX bus, it enters the safe mode. If this button is held for more than 3 seconds, the device enters the test mode. In order to perform a KNX Secure factory reset, while the device is in safe mode, press the button for 10 seconds until the programming LED changes its state.

Programming/Test LED: programming mode indicator (red). When the device enters the safe mode, it blinks (red) every half second. The test mode is indicated by the green color. During the start-up (reset or after KNX bus failure) and if the device is not in safe mode, it starts a blue blinking sequence.

GENERAL SPECIFICATIONS

CONCEPT		DESCRIPTION		
Type of device		Electric operation control device		
KNX supply	Voltage (typical)	29 VDC SELV		
	Voltage range	21-31 VDC		
	Maximum consumption	Voltage	mA	mW
		29 VDC (typical)	4.5	130.5
24 VDC ¹	10	240		
Connection type		Typical TP1 bus connector for 0.8 mm Ø rigid cable		
External power supply		Not required		
Operation temperature		0 .. +55 °C		
Storage temperature		-20 .. +55 °C		
Operation humidity		5 .. 95%		
Storage humidity		5 .. 95%		
Protection class / Overvoltage category		- / III (4000 V)		
Operation type		Continuous operation		
Device action type		Type 1		
Electrical stress period		Long		
Complementary characteristics		Class B		
Degree of protection / Pollution degree		IP20 / 2 (clean environment)		
Installation		Independent device to be mounted inside electrical panels with DIN rail (IEC 60715)		
Minimum clearances		Not required		
Response on KNX bus failure		Data saving according to parameterization		
Response on KNX bus restart		Data recovery according to parameterization		
Operation indicator		The programming LED indicates programming mode (red) and test mode (green). Each output LED indicates its status		
Weight		670 g		
PCB CTI index		175 V		
Housing material / Ball pressure test temperature		PC FR V0 halogen free / 75 °C (housing) - 125 °C (connectors)		

¹ Maximum consumption in the worst-case scenario (KNX Fan-In model).

OUTPUTS SPECIFICATIONS AND CONNECTIONS

CONCEPT		DESCRIPTION
Number of outputs		20
Output type / Disconnection type		Potential-free outputs through bistable relays with tungsten pre-contact / micro-interruption
Rated current per output		AC 16(6) A @ 250 VAC (4000 VA) DC 7 A @ 30 VDC (210 W)
Maximum load per output	Resistive	4000 W
	Inductive	1500 VA
Maximum inrush current		800 A/200 µs 165 A/20 ms
Different phases connection		Possibility of connecting different phases. It is not allowed to connect power supplies of different order, SELV with NO SELV, in the same block.
Maximum current per block		40 A
Short-circuit protection		NO
Overload protection		NO
Connection method		Screw terminal block (0.5 Nm max.)
Cable cross-section		1.5-4 mm ² (IEC) / 26-10 AWG (UL)
Outputs per common		1
Maximum response time		10 ms
Mechanical lifetime (min. cycles)		3 000 000
Electrical lifetime (min. cycles) ¹		100000 @ 8 A / 25000 @ 16 A (VAC)

¹ Lifetime values could change depending on the load type.

WIRING DIAGRAMS

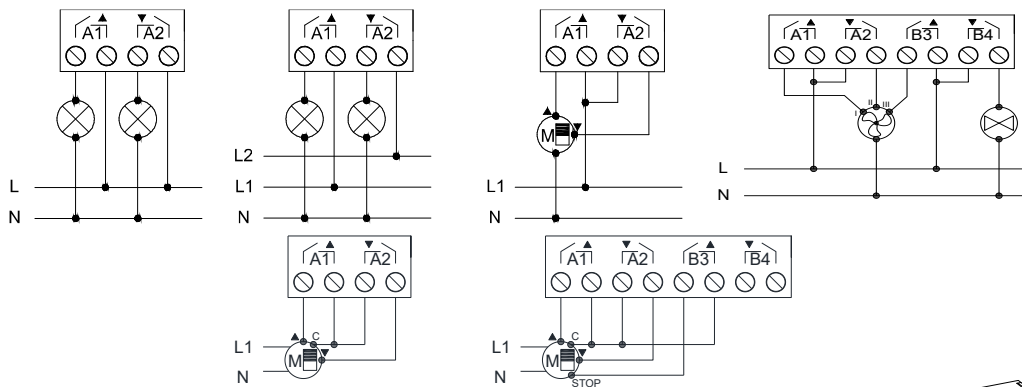
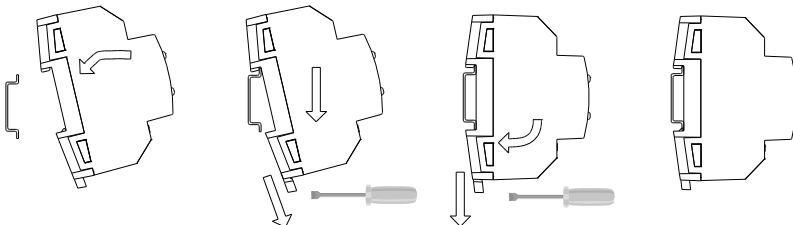

Figure 2: Wiring example (from left to right and up to down): 2 loads, 2 loads connected to different phases, shutter, fan coil, shutter with 2 dry contacts, shutter with 3 dry contacts.

⚠ In order to ensure the expected status of the relays, please check that the device is connected to the KNX bus before energizing the power circuit.

Attaching MAXinBOX 20 to DIN rail:



Removing MAXinBOX 20 from DIN rail:

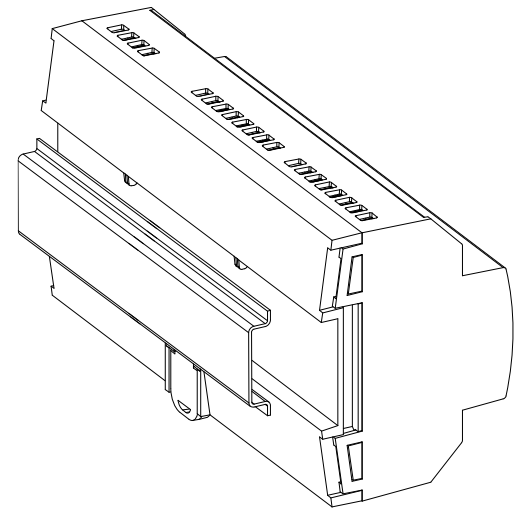
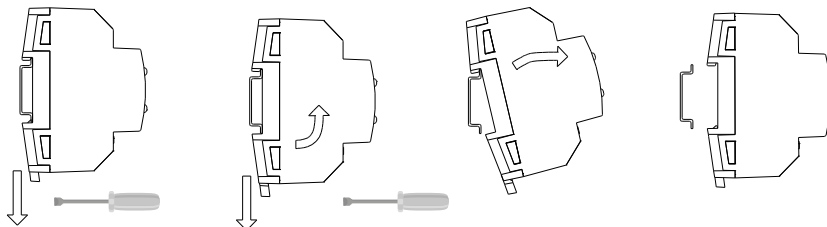

Figure 3: Mounting MAXinBOX 20 on DIN rail

SAFETY INSTRUCTIONS AND ADDITIONAL NOTES

- Installation should only be performed by qualified professionals according to the laws and regulations applicable in each country.
- Do not connect the mains voltage nor any other external voltage to any point of the KNX bus; it would represent a risk for the entire KNX system. The facility must have enough insulation between the mains (or auxiliary) voltage and the KNX bus or the wires of other accessories, in case of being installed.
- The home automation facility must be equipped with a device that ensures the omnipolar sectioning. Installation of a 16 A mini-circuit-breaker is recommended. To prevent accidents, it must remain open in case of manipulation of the device.
- Once the device is installed (in the panel or box), it must not be accessible from outside.
- Keep the device away from water (condensation over the device included) and do not cover it with clothes, paper or any other material while in use.
- The WEEE logo means that this device contains electronic parts and it must be properly disposed of by following the instructions at <https://www.zennio.com/en/legal/wEEE-regulation>.
- This device contains software subject to specific licences. For details, please refer to <https://zennio.com/licenses>.