

## FEATURES

- 4 individual outputs up to 20 A with current measurement
- Outputs suitable for capacitive loads, maximum 200 µF
- Possibility of connecting different phases in adjacent outputs
- Supports KNX Data Secure
- 2 Master Light controls
- Manual control for physical operation/actuation of the relay
- 20 logic functions
- Output timing
- Total data saving on KNX bus failure
- Integrated KNX BCU (TP1-256)
- Dimensions 67 x 90 x 70 mm (4 DIN units)
- DIN rail mounting according to IEC 60715 TH35, with fixing clamp
- Conformity with the CE, RCM directives (marks on the right side)

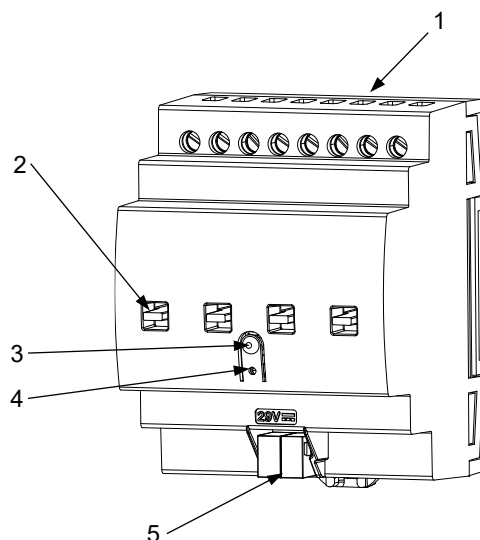

Figure 1: IndustrialBOX Current 4

1. Outputs      2. Actuation lever/handle      3. Programming button      4. Programming LED      5. KNX connector

Programming button: short press to set programming mode. If this button is held while plugging the device into the KNX bus, it enters the safe mode. In order to perform a KNX Secure factory reset, while the device is in safe mode, press the button for 10 seconds until the programming LED changes its state.

Programming LED: programming mode indicator (red). When the device enters the safe mode, it blinks (red) every half second. During the start-up (reset or after KNX bus failure) and if the device is not in safe mode, it starts a blue blinking sequence.

## GENERAL SPECIFICATIONS

CONCEPT		DESCRIPTION		
Type of device		Electric operation control device		
KNX supply	Voltage (typical)	29 VDC SELV		
	Voltage range	21-31 VDC		
	Maximum consumption	Voltage	mA	mW
		29 VDC (typical)	4.59	133.11
24 VDC <sup>1</sup>	10	240		
Connection type		Typical TP1 bus connector for 0.8 mm Ø rigid cable		
External power supply		Not required		
Operation temperature		0 .. +55 °C		
Storage temperature		-20 .. +55 °C		
Operation humidity		5 .. 95%		
Storage humidity		5 .. 95%		
Complementary characteristics		Class B		
Protection class / Overvoltage category		- / III (4000 V)		
Operation type		Continuous operation		
Device action type		Type 1		
Electrical stress period		Long		
Degree of protection / Pollution degree		IP20 / 2 (clean environment)		
Installation		Independent device to be mounted inside electrical panels with DIN rail (IEC 60715)		
Minimum clearances		Not required		
Response on KNX bus failure		Data saving according to parameterization		
Response on KNX bus restart		Data recovery according to parameterization		
Operation indicator		The programming LED indicates programming mode (red)		
Weight		337 g		
PCB CTI index		175 V		
Housing material / Ball pressure test temperature		PC FR V0 halogen free / 75 °C (housing) - 125 °C (connectors)		

<sup>1</sup> Maximum consumption in the worst-case scenario (KNX Fan-In model).

OUTPUTS SPECIFICATIONS AND CONNECTIONS		
CONCEPT		DESCRIPTION
Number of outputs		4
Output type / Disconnection type		Potential-free outputs through bistable relays / micro-interruption
Rated current per output		AC 20(7) A @ 250 VAC (5000 VA)
Maximum load per output	Resistive	5000 W
	Inductive	1750 VA
Maximum inrush current		500 A / 2 ms
Connections in adjacent outputs		Possibility of connecting different phases. It is not allowed to connect power supplies of different order, SELV with NO SELV.
Maximum current per device		80 A
Short-circuit protection		NO
Overload protection		NO
Current measure accuracy		2% ±20 mA
Connection method		Screw terminal block (0.5 Nm max.)
Cable cross-section		0.5-4 mm <sup>2</sup> (IEC) / 26-10 AWG (UL)
Outputs per common		1
Maximum response time		15 ms
Mechanical lifetime (min. cycles)		1 000 000
Electrical lifetime (min. cycles) <sup>1</sup>		100000 @ 20 A (VAC)

<sup>1</sup> Lifetime values could change depending on the load type.

## WIRING DIAGRAMS

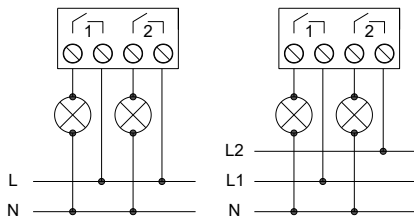

⚠ In order to ensure the expected status of the relays, please manually check the relays before energizing the power circuit.

Figure 2: Wiring example (from left to right): 2 loads and 2 loads connected to different phases

Attaching IndustrialBOX Current 4 to DIN rail:

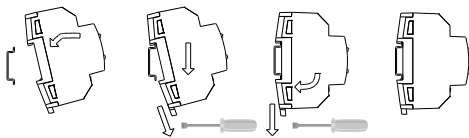

Removing IndustrialBOX Current 4 from DIN rail:

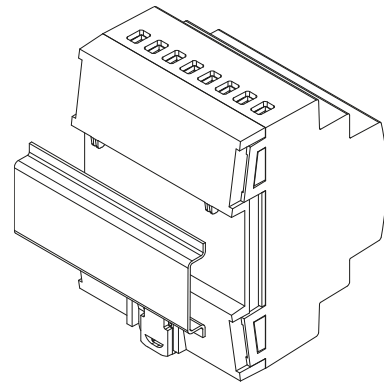
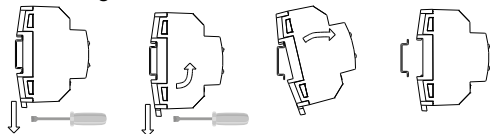

Figure 3: Mounting IndustrialBOX 4 Current on DIN rail

## SAFETY INSTRUCTIONS AND ADDITIONAL NOTES

- Installation should only be performed by qualified professionals according to the laws and regulations applicable in each country.
- Do not connect the mains voltage nor any other external voltage to any point of the KNX bus; it would represent a risk for the entire KNX system. The facility must have enough insulation between the mains (or auxiliary) voltage and the KNX bus or the wires of other accessories, in case of being installed.
- The home automation facility must be equipped with a device that ensures the omnipolar sectioning. Installation of a 20 A mini-circuit-breaker is recommended. To prevent accidents, it must remain open in case of manipulation of the device.
- Once the device is installed (in the panel or box), it must not be accessible from outside.
- Keep the device away from water (condensation over the device included) and do not cover it with clothes, paper or any other material while in use.
- The WEEE logo means that this device contains electronic parts and it must be properly disposed of by following the instructions at <https://www.zennio.com/en/legal/weee-regulation>.
- This device contains software subject to specific licences. For details, please refer to <https://zennio.com/licenses>.