

### FEATURES

- Control of 4 channels with up to 64 DALI ballasts per channel
- Single Master DALI-2 Controller
- Compatibility with color ballasts (DT8) and energy monitoring (DT51)
- Supports KNX Data Secure
- Ballast replacement allowed with automatic detection
- Error detection and monitoring (except multiaddress DALI ballasts)
- KCL, Burn-in, Stand-by and Auto-off functionality for each channel
- Optional manual dimming control
- External 110-240 VAC 50/60 Hz power supply for bus DALI
- Total data saving on KNX bus failure
- Integrated KNX BCU (TP1-256)
- Dimensions 67 x 90 x 79 mm (4.5 DIN units)
- DIN rail mounting according to IEC 60715 TH35, with fixing clamp
- DALI Standard certified according to IEC 62386
- Conformity with the CE, RCM directives (marks on the right side)

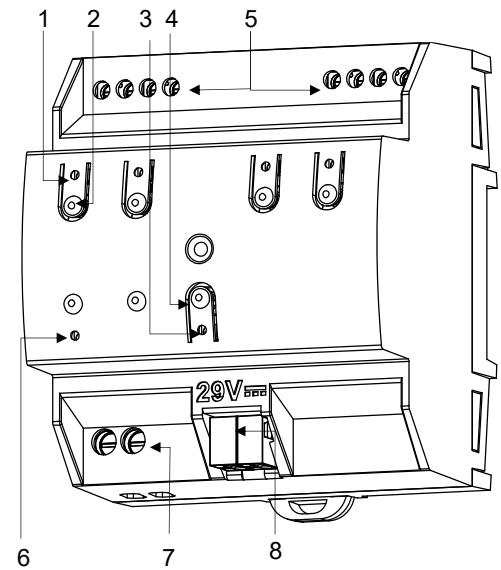

Figure 1: DALI BOX Broadcast 4CH v2

1. DALI channel status LED	2. DALI channel control button	3. Programming/Test LED	4. Programming/Test button
5. DALI channel output	6. External supply LED	7. External power supply	8. KNX connector

Programming/Test button: short press to set programming mode. If this button is held while plugging the device into the KNX bus, it enters the safe mode. If this button is held for more than 3 seconds, the device enters the test mode. In order to perform a KNX Secure factory reset, while the device is in safe mode, press the button for 10 seconds until the programming LED changes its state.

Programming/Test LED: programming mode indicator (red). When the device enters the safe mode, it blinks (red) every half second. The test mode is indicated by the green color. During the start-up (reset or after KNX bus failure) and if the device is not in safe mode, it emits a red flash.

### GENERAL SPECIFICATIONS

CONCEPT		DESCRIPTION		
Type of device		Electric operation control device		
KNX supply	Voltage (typical)	29 VDC SELV		
	Voltage range	21-31 VDC		
	Maximum consumption	Voltage	mA	mW
		29 VDC (typical)	3.3	95.7
24 VDC <sup>1</sup>	10	240		
Connection type		Typical TP1 bus connector for 0.8 mm Ø rigid cable		
External power supply	Voltage	110-240 VAC 50/60 Hz PF=0.5		
	Maximum consumption	175 mA @ 110 VAC / 100 mA @ 230 VAC		
Operation temperature		-5 .. +45 °C		
Storage temperature		-20 .. +55 °C		
Operation humidity		5 .. 95%		
Storage humidity		5 .. 95%		
Complementary characteristics		Class B		
Protection class / Overvoltage category		II / III (4200 V)		
Operation type		Continuous operation		
Device action type		Type 1		
Electrical stress period		Long		
Degree of protection		IP20, clean environment		
Installation		Independent device to be mounted inside electrical panels with DIN rail (IEC 60715)		
Minimum clearances		Not required		
Response on KNX bus failure		Data saving according to parameterization		
Response on KNX bus restart		Data recovery according to parameterization		
Operation indicator		The programming LED indicates programming mode (red) and test mode (green). Each output LED indicates its status (fixed = active output; flashing = error in the output). Power supply LED indicates the presence of supply voltage (green).		
Weight		221 g		
PCB CTI index		175 V		
Housing material		PC FR V0 halogen free		

<sup>1</sup> Maximum consumption in the worst-case scenario (KNX Fan-In model).

OUTPUTS SPECIFICATIONS AND CONNECTIONS OF DALI CHANNELS	
CONCEPT	DESCRIPTION
Number of channels	4
Output type / Voltage	DALI bus / 18 VDC FELV
Guaranteed current per channel <sup>2</sup>	125 mA
Maximum current per channel	250 mA
Guaranteed current per device	500 mA
Maximum DALI ballasts per channel <sup>3</sup>	64
Maximum cable length	300 m @ 1.5 mm <sup>2</sup> (IEC) / 15 AWG (UL)
Short-circuit protection	YES
Overload protection	YES
Over-voltage protection	YES
Connection method	Screw terminal block (0.5 Nm max.)
Cable cross-section	0.5-2.5 mm <sup>2</sup> (IEC) / 26-12 AWG (UL)

<sup>2</sup> It could be possible to increase this limit to 150mA as long as the guaranteed current per device is not exceeded.  
<sup>3</sup> One DALI address is considered per DALI ballast.

EXTERNAL POWER SUPPLY SPECIFICATIONS AND CONNECTIONS		
CONCEPT	DESCRIPTION	
Power supply protection fuse	Voltage	250 V
	Current	4 A
	Response type	F (Fast acting)
Connection method	Screw terminal block (0.5 Nm max.)	
Cable cross-section	1.5-4 mm <sup>2</sup> (IEC) / 26-10 AWG (UL)	

### WIRING DIAGRAMS

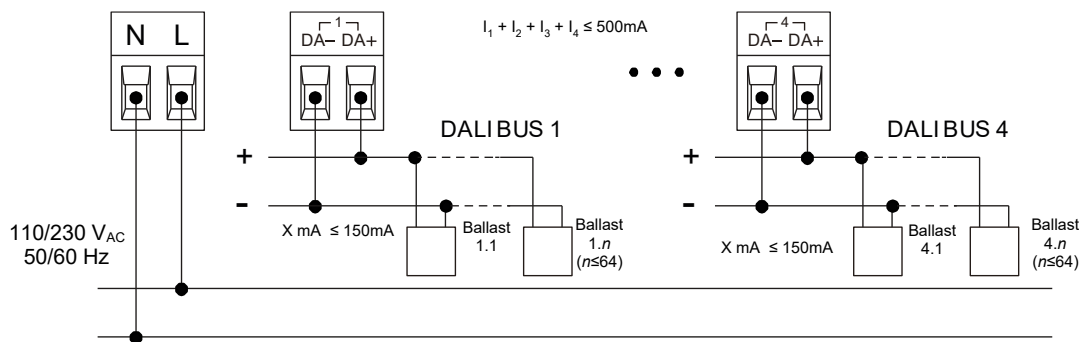

Attaching DALI BOX Broadcast 4CH v2 to DIN rail:

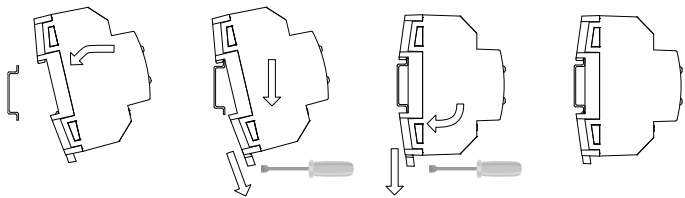

Removing DALI BOX Broadcast 4CH v2 from DIN rail:

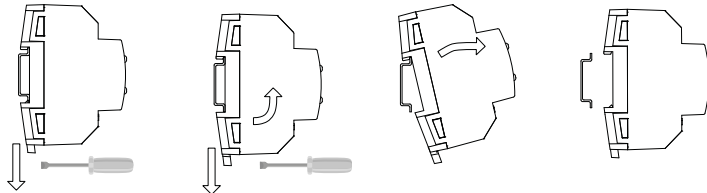

**Notes:**  
 ·Electrical connection between different DALI channels must be avoided.  
 ·In case of ballast replacement, please pay attention to the defined steps on the manual.

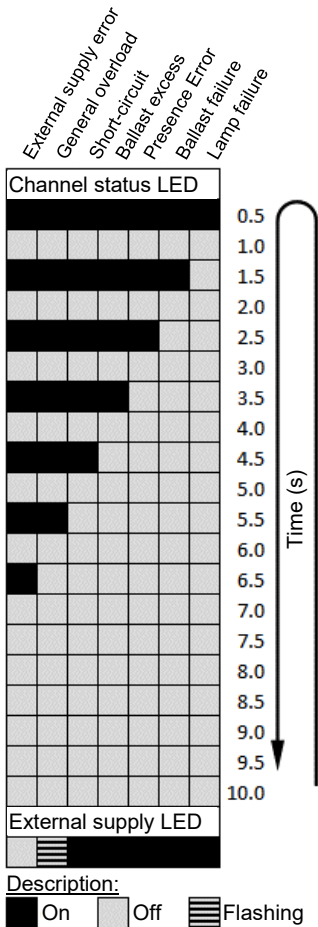

Figure 2. Error notifications

### SAFETY INSTRUCTIONS AND ADDITIONAL NOTES

- Installation should only be performed by qualified professionals according to the laws and regulations applicable in each country.
- Do not connect the mains voltage nor any other external voltage to any point of the KNX bus; it would represent a risk for the entire KNX system. The facility must have enough insulation between the mains (or auxiliary) voltage and the KNX bus or the wires of other accessories, in case of being installed.
- The home automation facility must be equipped with a device that ensures the omnipolar sectioning. Installation of a 10 A mini-circuit-breaker is recommended. To prevent accidents, it must remain open in case of manipulation of the device.
- The device has a short-circuit protection fuse that, in case of activation, should only be rearmed or replaced by the Zennio technical service.
- This device contains a security short-circuit proof transformer.
- Once the device is installed (in the panel or box), it must not be accessible from outside.
- For indoor use only.
- Keep the device away from water (condensation over the device included) and do not cover it with clothes, paper or any other material while in use.
- This device contains a security short-circuit proof transformer.
- The WEEE logo means that this device contains electronic parts and it must be properly disposed of by following the instructions at <https://www.zennio.com/en/legal/wEEE-regulation>.
- This device contains software subject to specific licences. For details, please refer to <https://zennio.com/licenses>.