

## FEATURES

- Interface for two DALI channels
- Possibility of controlling up to 64 DALI ballasts per channel
- Possibility of controlling up to 16 DALI inputs per channel
- Multi-Master DALI-2 Controller
- Compatibility with emergency lighting (DT1), color ballasts (DT8) and energy monitoring (DT51)
- Supports KNX Data Secure
- Scene sending and saving. HCL function
- Error detection and monitoring
- Burn-in, Stand-by and Auto-off functions
- Manual control through buttons and status indication through display
- 1.54" display (128 x 64 pixels) for settings and notifications
- External power supply of 110-240 VAC 50/60 Hz for bus DALI
- Total data saving on KNX bus failure
- Integrated KNX BCU (TP1-256)
- Size 67 x 90 x 79 mm (4.5 DIN units)
- DIN rail mounting according to IEC 60715 TH35, with fixing clamp
- DALI Standard certified
- Conformity with the CE, RCM directives (marks on the right side)

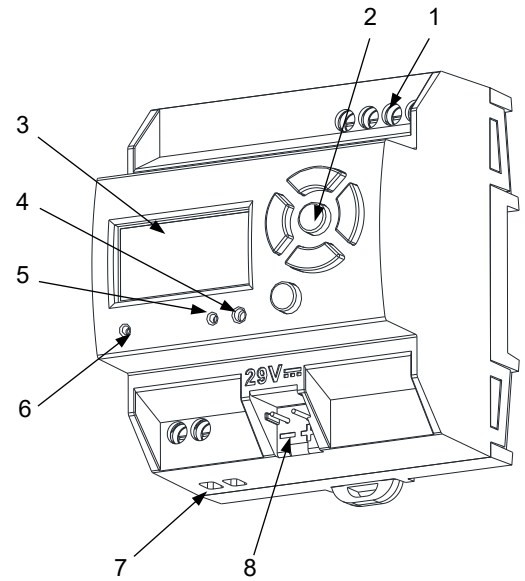

Figure 1: DALI BOX Interface 64 X2

1. DALI bus channel	2. Control buttons	3. Display	4. Programming button
5. Programming LED	6. Power supply indicator LED	7. External power supply	8. KNX connector

Programming button: short press to set programming mode. If this button is held while plugging the device into the KNX bus, it enters the safe mode. In order to perform a KNX Secure factory reset, while the device is in safe mode, press the button for 10 seconds until the programming LED changes its state.

Programming LED: programming mode indicator (red). When the device enters the safe mode, it blinks (red) every half second. During the start-up (reset or after KNX bus failure) and if the device is not in safe mode, it emits a red flash. The identification in a DALI commissioning is indicated in blue color.

## GENERAL SPECIFICATIONS

CONCEPT		DESCRIPTION	
Type of device		Electric operation control device	
KNX supply	Voltage (typical)	29 VDC SELV	
	Voltage range	21-31 VDC	
	Connection type	Typical TP1 bus connector for 0.8 mm Ø rigid cable	
	Maximum consumption	Voltage	mA
29 VDC (typical)		6,2	179.8
	24 VDC <sup>1</sup>	10	240
External power supply	Voltage	110-240 VAC 50/60 Hz PF=0.5	
	Maximum consumption	140 mA @ 110 VAC / 85 mA @ 230 VAC	
Operation temperature		-5 .. +45 °C	
Storage temperature		-20 .. +55 °C	
Operation humidity		5 .. 95%	
Storage humidity		5 .. 95%	
Complementary characteristics		Class B	
Protection class / Overvoltage category		II / III (4200 V)	
Operation type		Continuous operation	
Device action type		Type 1	
Electrical stress period		Long	
Degree of protection		IP20, clean environment	
Installation		Independent device to be mounted inside electrical panels with DIN rail (IEC 60715)	
Minimum clearances		Not required	
Response on KNX bus failure		Data saving according to parameterization	
Response on KNX bus restart		Data recovery according to parameterization	
Operation indicator		The programming LED indicates programming mode (red). The power supply LED indicates external power (green). Display allows both configuring the DALI system and supervising the current status.	
Weight		252 g	
PCB CTI index		175 V	
Housing material		PC FR V0 halogen free	

<sup>1</sup> Maximum consumption in the worst-case scenario (KNX Fan-In model).

## DALI OUTPUT SPECIFICATIONS AND CONNECTIONS

CONCEPT	DESCRIPTION
Number of channels	2
Output type / Voltage	DALI bus / 18 VDC FELV
Guaranteed current per channel	200 mA
Maximum current per channel	250 mA
Maximum DALI ballasts per channel	64
Maximum length of cable	300 m (@ 1.5 mm <sup>2</sup> )
Short-circuit protection	YES
Overload protection	YES
Over-voltage protection	YES
Connection method	Screw terminal block (0.5 Nm max.)
Cable cross-section	1.5-4 mm <sup>2</sup> (IEC) / 26-10 AWG (UL)

## EXTERNAL POWER SUPPLY SPECIFICATIONS AND CONNECTIONS

CONCEPT	DESCRIPTION	
Power supply protection fuse	Voltage	250 V
	Current	4 A
	Response type	F (Fast acting)
Connection method	Screw terminal block (0.5 Nm max.)	
Cable cross-section	1.5-4 mm <sup>2</sup> (IEC) / 26-10 AWG (UL)	

### WIRING DIAGRAMS

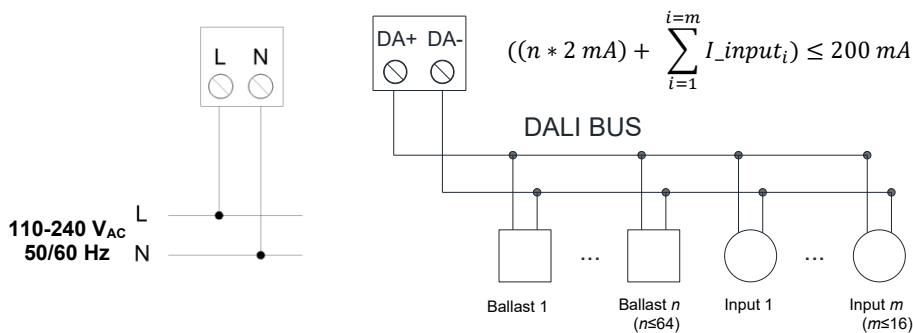

⚠ In case of ballast replacement, please follow the steps defined in the user manual.

⚠ In case of a DALI channel short circuit, the device will monitor the DALI channel in order to switch on the output at full current just as the short circuit is removed.

⚠ The total current consumed by the ballasts and inputs devices must not exceed the guaranteed current per channel.

⚠ It is recommended to not exceed a maximal current of 125 mA in input devices in order to maintain part of the available device's capacity for use of control gears.

Attaching DALI BOX Interface 64 X2 to DIN rail:

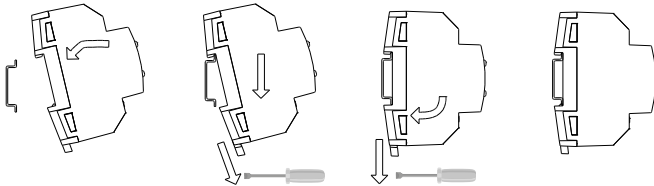

Removing DALI BOX Interface 64 X2 from DIN rail:

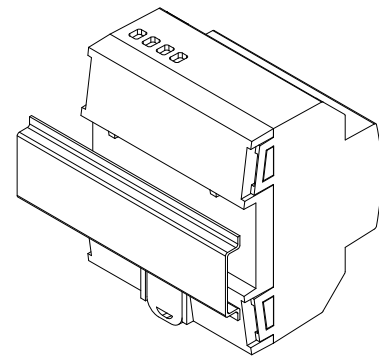
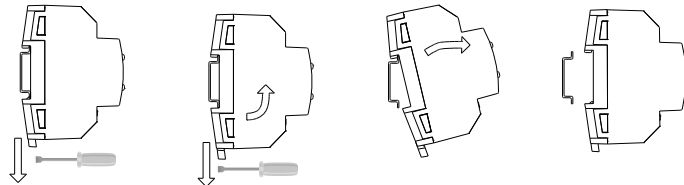

Figure 2: Mounting DALI BOX Interface 64 X2 on DIN rail

### SAFETY INSTRUCTIONS AND ADDITIONAL NOTES

- Installation should only be performed by qualified professionals according to the laws and regulations applicable in each country.
- Do not connect the mains voltage nor any other external voltage to any point of the KNX bus; it would represent a risk for the entire KNX system. The facility must have enough insulation between the mains (or auxiliary) voltage and the KNX bus or the wires of other accessories, in case of being installed.
- The home automation facility must be equipped with a device that ensures the omnipolar sectioning. Installation of a 10 A mini-circuit-breaker is recommended. To prevent accidents, it must remain open in case of manipulation of the device.
- The device has a short-circuit protection fuse that, in case of activation, should only be rearmed or replaced by the Zennio technical service.

This device contains a security short-circuit proof transformer.

• Once the device is installed (in the panel or box), it must not be accessible from outside.

For indoor use only.

• Keep the device away from water (condensation over the device included) and do not cover it with clothes, paper or any other material while in use.

The WEEE logo means that this device contains electronic parts and it must be properly disposed of by following the instructions at <https://www.zennio.com/en/legal/weee-regulation>.

• This device contains software subject to specific licences. For details, please refer to <https://zennio.com/licenses>.