

## RemoteBOX

Device for remote control of KNX installation

ZSYRBOX

Application Program Version: [4.3]

User Manual Version: [4.3]\_a

[www.zennio.com](http://www.zennio.com)

# CONTENTS

---

Contents .....	2
Document updates.....	5
1 Introduction .....	6
1.1 RemoteBOX .....	6
1.2 Functionality.....	9
1.3 Initialisation and Start-up.....	10
1.3.1 Loading Screen .....	11
1.3.2 EULA .....	11
1.3.3 Firmware update without application program.....	11
1.3.4 LEDs and buttons in RemoteBOX .....	12
2 Configuration.....	13
2.1 General .....	13
2.1.1 Web Server .....	13
2.1.2 Configuration.....	14
2.1.3 Time Configuration.....	17
2.1.4 Locale .....	19
2.1.5 Security.....	23
2.1.6 Remote Control .....	26
2.1.7 Schedulers .....	27
2.1.8 Energy Monitor .....	30
2.1.8.1 Individual consumption n.....	34
2.1.9 Sonos .....	35
2.1.10 Update Setting .....	35
2.1.10.1 Firmware Update.....	36
2.1.10.2 Licence Setup.....	36
2.1.10.3 Import and export translations .....	37
2.1.10.4 Custom Icons .....	38
2.1.11 IP Configuration.....	40
2.1.12 Avanced.....	42
2.1.12.1 Pop-ups.....	43

2.1.12.1.1	Pop-Up n .....	44
2.2	Display .....	46
2.2.1	Pages .....	46
2.2.1.1	Menu .....	47
2.2.1.2	Configuration Page .....	48
2.2.1.2.1	Device.....	51
2.2.1.2.2	Profile.....	53
2.2.1.3	Page <i>n</i> .....	53
2.2.1.3.1	Events Log .....	55
2.2.1.3.1.1	N Event.....	57
2.2.2	Controls .....	58
2.2.2.1	Control <i>i</i> .....	58
2.2.2.1.1	INDICATORS .....	60
2.2.2.1.1.1	Binary .....	61
2.2.2.1.1.2	Enumeration.....	61
2.2.2.1.1.3	Numerical Indicators .....	62
2.2.2.1.1.4	Text.....	63
2.2.2.1.2	1-BUTTON CONTROL.....	64
2.2.2.1.2.1	Switch.....	64
2.2.2.1.2.2	Two Objects (Short Press/Long Press) .....	65
2.2.2.1.2.3	Hold & Release.....	65
2.2.2.1.2.4	Scene .....	66
2.2.2.1.2.5	Constant Numerical Controls .....	67
2.2.2.1.2.6	Room State.....	68
2.2.2.1.2.7	Enumeration.....	68
2.2.2.1.3	2-BUTTON CONTROL.....	69
2.2.2.1.3.1	Switch.....	70
2.2.2.1.3.2	Switch + Indicator.....	70
2.2.2.1.3.3	Two Objects (Short Press/Long Press) .....	72
2.2.2.1.3.4	Numerical Controls .....	72
2.2.2.1.3.5	Enumeration.....	74
2.2.2.1.3.6	Two Scene .....	74
2.2.2.1.3.7	Shutter .....	75
2.2.2.1.3.8	Dimmer .....	77

2.2.2.1.4	CLIMATE CONTROL .....	79
2.2.2.1.4.1	Temperature Setpoint.....	79
2.2.2.1.4.2	Mode.....	81
2.2.2.1.4.3	Fan Control.....	83
2.2.2.1.4.4	Special Mode.....	86
2.2.2.1.5	OTHER .....	87
2.2.2.1.5.1	RGB Control.....	87
2.2.2.1.5.2	RGBW Control .....	88
2.2.2.1.5.3	Page Direct Link.....	89
2.2.2.1.5.4	Alarm.....	90
2.2.2.1.5.5	Chronothermostat .....	91
2.2.2.1.5.6	Scheduler .....	93
2.2.2.1.5.7	Macro.....	94
2.2.2.1.5.8	Timer.....	97
2.2.2.1.5.9	Energy Monitor .....	100
2.2.2.1.5.10	Keypad.....	100
2.2.2.1.5.11	Multimedia.....	101
2.3	Logic functions.....	104
ANNEX I.	Remote Control via IP .....	105
ANNEX II.	Graphs.....	109
ANNEX III.	Energy monitor configuration.....	113
ANNEX IV.	Communication Objects .....	115

## DOCUMENT UPDATES

Versión	Modificaciones	Página(s)
[4.3]_a	<ul style="list-style-type: none"><li>• Sonos functionality</li><li>• Energy monitor improvements</li><li>• Graph comparison</li><li>• New event log</li><li>• Pushable icons on 2-button controls</li><li>• Double scene control</li></ul>	-
[4.1]_b	<ul style="list-style-type: none"><li>• Added comparative table between RemoteBOX and Z50, Z70 v2 and Z100</li></ul>	-
[4.1]_a	<ul style="list-style-type: none"><li>• First version of the document derived from Z50, Z70 v2 y Z100</li></ul>	-

# 1 INTRODUCTION

---

## 1.1 REMOTEBOX

---

**RemoteBOX** are the easily and intuitively controllable high-performance **device** from Zennio. Their features and functionalities make them the ideal all-in-one solution for the control of KNX installations without a display via an internet-connected mobile device.

Inside the remote control application, the connection to the device is made and the graphical interface is accessed.

The most outstanding features of this device are:

- **Remote control** from a mobile device, with the possibility of administrator pairing.
- Multiple **direct-action functions**, fully customisable.
- Control distribution across up to **12 customisable pages + 1 configuration page**.
- **Customised icons**.
- Full **climate** management.
- **Scene** control.
- **Alarm** control.
- **Light/Dark** theme.
- **Chronothermostat**.
- **Direct links** to other pages.
- **Locale and language** configuration.
- **Pop-ups**.
- **Celsius and Fahrenheit scales** for the on-screen temperature indicators, being possible to select them in parameters or through communication object.

- **Heartbeat** or periodic “still-alive” notification.
- **Logic functions.**
- Possibility of **scheduling** actions.
- **Macros.**
- **Graphs** associated with controls.
- **Energy monitor.**
- **KNX Secure:** for detailed information about the functionality and the configuration of the KNX Secure, please refer to the specific manual “**KNX Secure Guide**” available in the RemoteBOX product section at the Zennio website ([www.zennio.com](http://www.zennio.com)).

There are also additional functionalities that require the use of a license in order to operate:

- **Number of controls** available: by default the basic remote control licence includes 100 controls, expandable with a new licence.
- **Voice Control.**

The following table lists the main features and functionalities of the three touch screens and RemoteBOX.

	<b>Z50</b>	<b>Z70 v2</b>	<b>Z100</b>	<b>RemoteBOX</b>
<b>Display size</b>	5"	7"	10"	Depends on the mobile device
<b>Display resolution</b>	480x854 px	1280x800 px	1280x800 px	-
<b>Menu grid</b>	4x3/3x4	3x4	3x4	1, 2, 3 or 4 columns (depends on the mobile device)
<b>Page grid</b>	4x2/2x4	3x4	3x4 or 4x5	1, 2, 3 or 4 columns (depends on the mobile device)
<b>Display orientation</b>	Vertical/Horizontal	Horizontal	Horizontal	Vertical/Horizontal (depends on the mobile device)

<b>Maximun number of normal pages</b>	12	12	12	12
<b>Maximun controls per page</b>	8	12	12 or 20	20
<b>Screensaver</b>	✓	✓	✓	-
<b>Automatic page shaping</b>	✓	✓	✓	-
<b>Touchscreen locking</b>	✓	✓	✓	-
<b>Night mode</b>	✓	✓	✓	-
<b>Custom icons</b>	✓	✓	✓	✓
<b>Cleaning function</b>	✓	✓	✓	-
<b>Speakers</b>	✓	✓	✓	-
<b>Welcome back object</b>	✓	✓	✓	-
<b>Multilanguage</b>	✓	✓	✓	✓
<b>Technical alarms</b>	✓	✓	✓	✓
<b>Timers</b>	✓	✓	✓	✓
<b>USB</b>	✓	✓	✓	-
<b>Internal temperature probe</b>	✓	✓	-	-
<b>Proximity sensor</b>	✓	✓	✓	-
<b>Luminosity sensor for brightness adjustment</b>	✓	✓	✓	-
<b>Number of analogue-digital inputs</b>	2	4	4	-
<b>Thermostats</b>	2	2	2	-
<b>Remote control (Ethernet)</b>	Under license	Under license	Under license	Under license
<b>Video intercom and internal calls</b>	Under license	Under license	Under license	-
<b>Voice control</b>	Under license (*)	Under license (*)	Under license (*)	Under license (*)

(\*) Remote control license required

Table 1. Z50, Z70 v2, Z100 and RemoteBOX features and functionalities.

## 1.2 FUNCTIONALITY

---

Screens application program feature the following functions:

- **12 General-Purpose Pages, with up to 20 Fully-Customisable Boxes each,** which the integrator may configure as indicators or controls.

- **Indicators:**

- Binary.
- Enumeration.
- Integer.
- Percentage.
- Float.
- Temperature.
- Cost.
- Tex

- **1-Button Controls:**

- Switch.
- Two Object (Short Press/Long Press).
- Hold & Release.
- Enumeration.
- Scene.
- Constant (Counter / Scaling / Float).
- Room State.

- **2-Button Controls:**

- Switch.
- Switch + Indicator (Counter / Scaling / Float / Temperature)
- Two Object (Short Press/Long Press).
- Counter.
- Scaling.
- Float.
- Enumeration.
- Two Scenes.
- Shutter.
- Dimmer.

- **Climate Specific Controls:**

- Temperature Setpoint control.
- Mode.
- Special modes.
- Fan.

- **Other Controls:**

- RGB Control.
- RGBW Control.
- Page Direct Link.
- Chronothermostat.
- Macro.
- Energy monitor.
- Alarm.
- Scheduler.
- Timer
- Keypad
- Multimedia

- **1 Configuration Page** (optional), which contains the time/date settings, and the brightness and volume adjustment, among others.

### 1.3 INITIALISATION AND START-UP

---

The device incorporates **two separate microcontrollers**, one of which focuses on interfacing with the KNX bus and on running the application program itself, while the second one is dedicated to running the firmware that implements the operating system and the management of the peripherals.

Therefore, the start-up or upgrade of these devices may consist in two phases:

- Downloading the **application program** (from ETS),

**Note:** *although the device will not turn functional until it is powered with the external supply, the KNX bus power should be enough to perform downloads from ETS (application program, group addresses, etc.).*

- Downloading the **firmware**:

- Through the network from a PC running the Windows operating system, by means of the Ethernet adapter bundled with the original packaging of the device.

For further information about the firmware updating process see section 2.1.9.

For detailed information about the technical features, as well as on security and installation procedures, please refer to the device **Datasheet**, bundled within the device packaging and also available at [www.zennio.com](https://www.zennio.com).

### 1.3.1 LOADING SCREEN

---

During startup, the device will display a loading screen showing information about the startup status, as well as the following information:

- Application program and firmware version.
- Physical address of the device.
- Serial number.
- IP and connection status.
- Installed licenses.

This loading screen will also be used to indicate whether the screen is booting up, whether there is a bus failure, or whether there is an error, such as incompatibility between the installed versions.

### 1.3.2 EULA

---

After the first start-up of the device, a dialog with the text EULA (End User License Agreement) will be displayed.

The legal conditions of use described in EULA must be accepted by the end user before using the device, so during the installation must be postponed. Once postponed, the EULA dialog will be displayed again after two hours or after a power failure.

As long as the EULA is not accepted or postponed, screen navigation is not allowed.

If the terms of use change, a dialog with the new text EULA to be accepted will be displayed on the screen.

### 1.3.3 FIRMWARE UPDATE WITHOUT APPLICATION PROGRAM

---

A firmware download is possible without also downloading the application program version. This update makes it possible to easily install improvements to the device.

**Notes:**

- To install new functionalities that depend on new parameters, it is necessary to download the application program.
- This functionality is only valid for updating to higher versions, never for downgrading to lower firmware versions. In the latter case it will be necessary to install the application program version as well.

**1.3.4 LEDS AND BUTTONS IN REMOTEBOX**

RemoteBOX has 4 LEDs on the top of the enclosure with the following functionality:





		IP		L1
	No Synchronization	Device without IP	Without server connection or without "Remote" licence	N/D
	Synchronization in progress	N/A	Server connection in progress	N/D
	Successful synchronization	Device with IP	Successful server connection	N/D

Table 2. LEDs Status

**Notes:**

- To be able to connect to RemoteBOX, the first 3 LEDs must be green.
- The synchronisation LED indicates whether the loaded application program and firmware are compatible.

The device also has a generic reset button that allows the following actions to be performed:

- Confirm the Webserver Tool password reset. To do this, it is necessary to have first made the password reset request from Webserver Tools.

## 2 CONFIGURATION

---

After importing the corresponding database in ETS and adding the device into the topology of the desired project, the configuration process begins by entering the Parameters tab of the device.

### 2.1 GENERAL

---

This tab is divided into multiple screens, all of which contain a set of global parameters regarding the general functionality of the device, and therefore not specifically related to a particular page of the user interface.

#### 2.1.1 WEB SERVER

---

This tab enables or disables the web server where some functionalities such as data logs, licenses, etc. are managed.

#### ETS PARAMETERISATION

---

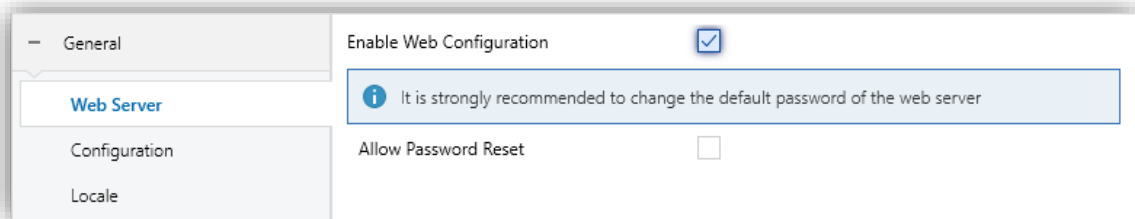

Figure 1. General. Web Server

The following parameters are shown:

- **Enable Web Configuration** [[disabled](#) / [enabled](#)]<sup>1</sup>: enables or disables access to “Webserver Tools”, from which certain configuration and monitoring actions can be performed.
- **Allow Password Reset** [[disabled](#) / [enabled](#)]: enables the password for accessing the Web server to be set to the factory default.

---

<sup>1</sup> The default values of each parameter will be highlighted in blue in this document, as follows: [[default](#) / *rest of options*].

Please refer to the user manual “**Webserver Tools**” (available in the product section at the Zennio homepage, [www.zennio.com](http://www.zennio.com)) for detailed information about its functionality and the configuration.

**Note:** *in the event of a supply failure, the connection with the server will be lost, and waiting for the device to recover its generic IP to access it again will be necessary.*

## 2.1.2 CONFIGURATION

The "Configuration" tab contains general settings. Most are checkboxes for enabling/disabling other functionalities.

### ETS PARAMETERISATION

General	Password for Administrator Privileges	<input type="text"/>
Web Server	Logic Functions	<input type="checkbox"/>
Configuration	Heartbeat (Periodic Alive Notification)	<input type="checkbox"/>
Time Configuration	Device Recovery Objects (Send 0 and 1)	<input type="checkbox"/>
Locale	Default Theme (After Download)	<input checked="" type="radio"/> Light <input type="radio"/> Dark
Security	Icons Type	<input checked="" type="radio"/> Colourful <input type="radio"/> Monochromatic
Remote Control	Show Time	<input type="checkbox"/>
Update Settings	Show Temperature	<input checked="" type="radio"/> No <input type="radio"/> External Value
IP Configuration	Update Objects	Disabled
Display	Schedulers	<input type="checkbox"/>
	Energy Monitor	<input type="checkbox"/>
	Sonos	<input type="checkbox"/>
	Advanced Configuration	<input type="checkbox"/>

Figure 2. General. Configuration

The following parameters are shown:

- **Password for Administrator Privileges:** sets the administrator password for the device.
- **Logic Functions** [*disabled / enabled*]: enables or disables de “Logic Functions” tab in the tree on the left. For more information, see section 2.3.

- **Heartbeat (Periodic Alive Notification)** [[disabled](#) / [enabled](#)]: incorporates a one-bit object to the project (“**[Heartbeat] Object to Send ‘1’**”) that will be sent periodically with value “1” to notify that the device is still working (*still alive*).

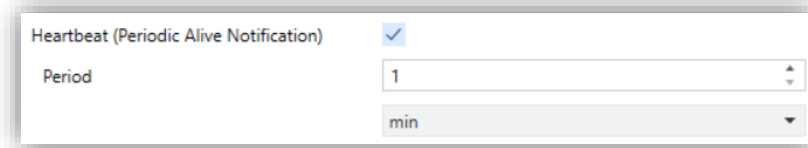

Figure 3. Heartbeat

**Note:** *the first sending after download or bus failure takes place with a delay of up to 255 seconds, to prevent bus overload. The following sendings match the period set.*

- **Device Recovery Objects (Send 0 and 1)** [[disabled](#) / [enabled](#)]: this parameter lets the integrator activate two new communication objects (“**[Heartbeat] Device Recovery**”), which will be sent to the KNX bus with values “0” and “1” respectively whenever the device begins operation (for example, after a bus power failure). It is possible to parameterise a **delay** [[0...255](#)] for this sending.

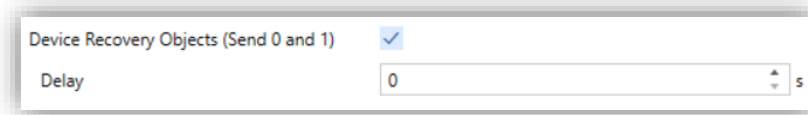

Figure 4. Device Recovery Objects

**Note:** *after download or bus failure, the sending takes place with a delay of up to 6,35 seconds plus the parameterised delay, to prevent bus overload.*

- **Default Theme (After Download)** [[Light](#) / [Dark](#)]: enables choosing the device theme after download.
- **Icons Type** [[Colourful](#) / [Monochromatic](#)]: enables to choose whether the set of icons will be displayed in color or grayscale.

**Note:** *even if the monochrome option is chosen, some icons will still keep the colour, such as RGB or some pop-up icons.*

- **Show Time** [[disabled](#) / [enabled](#)]: permits setting whether the current time is displayed in the upper-left corner of any page or not.

**Important:** *the time will not be displayed on the top bar until both a time and a valid date have been set.*

- **Show Temperature** [[No](#) / [External Value](#)]: sets whether the current temperature should show or not in the upper right corner of every page. If “[External Value](#)” is chosen, an object named “[**General**] **External Temperature**” will be enabled, so that it can be grouped with any other object that sends temperature values.
  
- **Update Objects**: enables the sending of read requests to update status objects and indicators. There are four options available, some of them with a configurable delay:
  - [[Disabled](#)]: no read request, therefore objects are not updated.
  - [[After Programming](#)]: read requests are sent after a complete or partial download (or when pressing the reset button in the configuration page, if set as “[Parameters Reset](#)”, see section 2.2.1.2.1).
  - [[After Reset](#)]: read request are sent when a reset occurs (bus failure, the Reset Device ETS option or when pressing the reset button in the configuration page, if set as “[Application Reboot](#)”, see section 2.2.1.2.1), after the parameterised **delay** [[0...10...65535](#)] [[s / min / h](#)].
  - [[After Programming and Reset](#)]: combination of the two above options.
  
- **Schedulers** [[disabled](#) / [enabled](#)]: enables schedulers functionality. When enabled, a new tab is added in the tree on the left. See section 2.1.72.1.6.
  
- **Energy Monitor** [[disabled](#) / [enabled](#)]: enables energy monitor functionality. When enabled, a new tab is added in the tree on the left. See section 2.1.8.
  
- **Sonos** [[disabled](#) / [enabled](#)]: enables the Sonos gateway functionality for Sonos device control. If enabled, a new tab is added (see section 2.1.9).
  
- **Advanced Configuration** [[disabled](#) / [enabled](#)]: enables “Advanced” tab. See section 2.1.11.

The project topology shows the following objects by default:

- “[General] Time of Day”: 3-byte object for setting the internal time of the device, for example, by linking it to a KNX clock. This object is also automatically sent after time changes made by the user from the device itself.

**Note:** *although the DPT of this object considers a field for setting the day of the week, the device calculates it from the date and therefore ignores that field.*

**Important:** *RemoteBOX does not have an RTC clock or battery to keep track of the time in the absence of power. Therefore, it is important to **receive the time periodically** from a device that obtains it through NTP and/or has a battery to prevent delays during bus failures.*

- “[General] Date”: 3-byte object for setting the internal date of the device, for example, by linking it to a KNX clock. This object is also automatically sent after date changes made by the user from the device itself.
- “[General] Scene: Send” and “[General] Scene: Receive”: objects for respectively sending and receiving scene values from/to the KNX bus whenever it is necessary.
- “[General] Localization – Select” and “[General] Translations – Select”: 4-byte and 2-bytes objects to change, respectively, the locale and the language in the screen (see section 2.1.3).
- “[Profile] Theme”: 1-byte object to change the theme used in the device.
- “[Profile] Volume”: 1-byte percentage object to change the volume at which the user sounds of device will be emitted.
- “[C1] Switch - Status”: object associated with Control 1 enabled by default.

### 2.1.3 TIME CONFIGURATION

---

This tab configures everything related to the time configuration (NTP clock, time zone, etc.).

The sunrise and sunset functionality is also enabled, which sends a 1-bit value to the bus each day at sunrise and sunset. This requires configuring the location where the device is located to send these objects accurately.

## ETS PARAMETERISATION

The screenshot shows a configuration interface with a sidebar on the left containing menu items: General, Web Server, Configuration, Time Configuration (highlighted), Locale, Security, and Remote Control. The main content area is titled 'Time Configuration' and includes the following settings:

- Synchronise Clock Master via NTP:**
- Select NTP Server:**
- Date and Time Periodical Sending:** 10 x 1 min
- Sunrise/Sunset:**
- TIME ZONE:**
  - Time Zone:** (UTC+01:00) Brussels, Copenhagen, Madrid, Paris
  - Daylight Saving Time (DST):**

Figure 5. Time Configuration

- **Synchronize Clock Master via NTP** [*disabled* / *enabled*]: if enabled, the device will update the date and time obtained from the NTP server according to the configured time zone. In addition, the following parameters will be displayed:
  - **Select NTP Server** [*disabled* / *enabled*]: allow the use of a specific NTP server for date and time requests. If not enabled, the default option defined by the manufacturer will be used.
    - **Domain of NTP Server** [*time.aws.org*]: NTP server used for internal clock synchronisation.
  - **Date and Time Periodical Sending** [*0 ... 10 ... 65535*] [*x 1 min*]: time period after which the date and time objects (“**[General] Date**” and “**[General] Time of Day**”) will be sent to the bus.

### TIME ZONE

- **Time Zone:** drop-down list to select a time zone from the UTC (Coordinated Universal Time) time standard.
- **Daylight Saving Time (DST)** [*disabled*] / [*disabled* / *enabled*]: enables or disables the automatic time change during the summer season. It will only be available in the time zones that have summer time changeover.
- **Sunrise/Sunset** [*disabled* / *enabled*]: enables the sunrise and sunset functionality. When enabled, the following parameters are displayed for configuring the location where the device is located:

### LOCATION

- **Latitude** [*North* / *South*]

- **Degrees [0 - 90°]** [0... 40 ... 90]
- **Minutes [0 – 59']** [0... 25 ... 59]
- **Longitude [East / West]**
  - **Degrees [0 - 180°]** [0... 3 ... 180]
  - **Minutes [0 – 59']** [0... 42 ... 59]

With the sunrise/sunset functionality, the following parameters will also be shown:

- **Sunrise/sunset objects [disabled / enabled]**: enabling this option displays the following:
  - **Binary Objects [disabled / enabled]**: enables the sending of the binary objects "[Sunrise/Sunset] Event at Sunrise" and "[Sunrise/Sunset] Event at Sunset" to the bus when the sunrise and sunset time is reached, being possible to configure the value to be sent in each case.
  - **Scene Object [disabled / enabled]**: sets the scenes to be sent through the general scene object when the sunrise and sunset times are reached.
- **Azimuth/Elevation Objects [disabled / enabled]**: activates the "[Sun] Azimuth" and "[Sun] Elevation" objects, which allows the position of the sun to be sent to the bus for the location configured in the "Time settings" tab.
  - **Sun Position Periodic Sending [1 ... 10 ... 255] [x 1 min]**: time period at which the sun's position objects are transmitted.

#### 2.1.4 LOCALE

---

The **locale** consists of a language and region identifier, which will determine the language and how certain visual aspects of the device are displayed, such as:

- The temperature scale: Celsius or Fahrenheit.
- Time format: 12 or 24 hours.
- Date format: dd-mm-yyyy, mm-dd-yyy o yyyy-mm-dd.
- Use of a point (.) or a comma (,) for decimal separation (except in temperature that will always be shown with a point as separator).

- Position of the currency symbol in cost indicators.
- Language of all the texts shown on the screen.

**Example 1:** *Locale: es-ES → Language: Spanish – Region: Spain.*

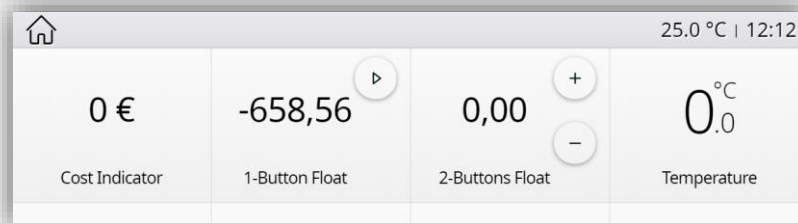

Figure 6. Locale es-ES

**Example 2:** *Locale: en-US → Language: English – Region: USA.*

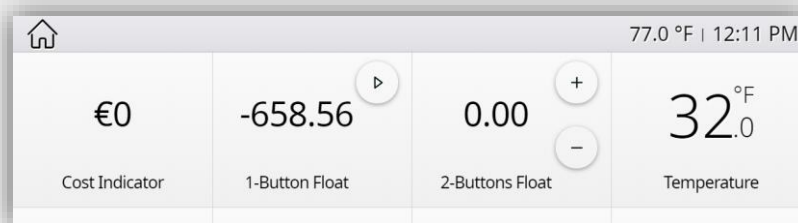

Figure 7. Locale en-US

The **locale** configuration can be selected through three types of communication objects:

- **A 1-byte object.** Enumerated to select **the locale and the language** from any of the configured in ETS.
- **A 2-bytes object.** Allows changing the **language** without affecting the region.
- **A 4-bytes object.** Allows changing **the locale and the language** by sending a language-region pair of values.

**Note:** *if a language change is made while a pop-up is open, this change will not take effect until the pop-up is closed.*

Please refer to section 2.1.9.3 for detailed information about the process of importing and exporting language translation files.

## ETS PARAMETERISATION

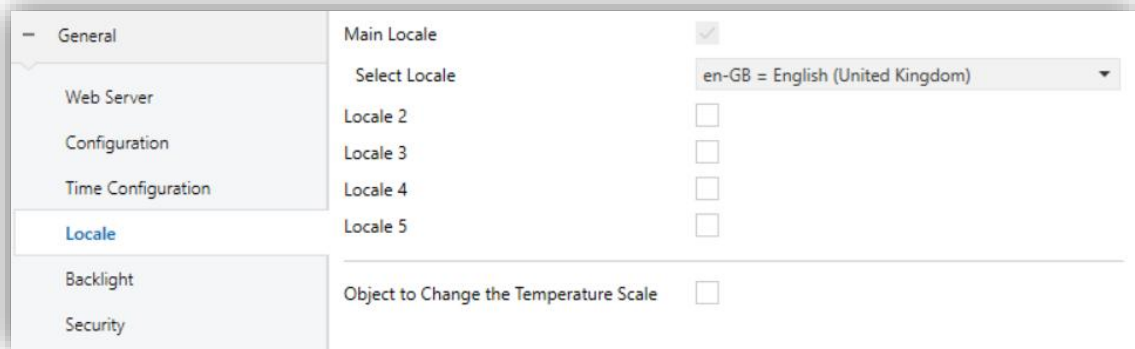

Figure 8. Locale

- **Main Locale** *[enabled]*: read-only parameter to make it evident that the main locale is always enabled.
  - **Select Locale**: list of the available locales.
- **Locale X** *[disabled / enabled]*: enables the additional locale X.
  - **Select Locale**: list of the available locales.

The language and locale are changed via the following communication objects:

- **1-byte object “[General] Localization - Select”**. To select the locale and the language from any of the configured in ETS.
  - The expected values in this object are fixed, from 0 to 4. When one of these values is received, the texts of the file `'text_language-region.xlf'` corresponding to the regional configuration associated with this value will be loaded.
  - If the received value does not correspond to any enabled locale, the main locale will be loaded.

**Note:** *this object is only available if more than one locale is enabled in ETS.*

- **4-bytes object “[General] Localization - Select”**.
  - The values expected by this object are four characters, **language-region** pair, corresponding to ISO 639-1 and 3166-1 respectively.
  - When a valid language-region code is received, the texts from the `'text_language-region.xlf'` file and the indicated region will be loaded. In case there is not that file, the main locale configuration will be loaded. If the region

does not correspond to the language or it is not valid, the default region associated with that language will be set (and the language file 'text\_language-ZZ.xlf', if it exists).

- **2-bytes object "[General] Translations - Select"**. To change the Language without affecting the region.
  - The values expected by this object are the language code corresponding to ISO 639-1.
  - When a valid language code is received, the texts from the 'text\_language-ZZ.xlf' file will be loaded. In case there is not that file, the language of the main locale configuration (texts from ETS) will be loaded.

**Example:**

**Imported files:** 'text\_es-ES.xlf', 'text\_es-ZZ.xlf' y 'text\_es-AR.xlf'.

**ETS Parameterization:**

Main Locale: en-GB

Locale 2: es-AR

Locale 3: fr-FR

1-byte object: 1 → Language: 'text\_es-AR.xlf' – Region: Argentina.

1-byte object: 2 → Language: 'dflt.xlf' (ETS texts) – Region: Great Britain.

1-byte object: 4 → Language: 'dflt.xlf' (ETS texts) – Region: Great Britain.

2-byte object: en → Language: 'dflt.xlf' (ETS texts) – Region: No change.

2-byte object: es → Language: 'text\_es-ZZ.xlf' – Region: No change.

2-byte object: fr → Language: 'dflt.xlf' (ETS texts) – Region: No change.

4-byte object: es-ES → Language: 'text\_es-ES.xlf' – Region: Spain

4-byte object: es-AR → Language: 'text\_es-AR.xlf' – Region: Argentina

4-byte object: fr-FR → Language: 'dflt.xlf' (ETS texts) – Region: Great Britain.

4-byte object: es-VE → Language: 'dflt.xlf' (ETS texts) – Region: Great Britain

4-byte object: es-aa → Language: 'text\_es-ZZ.xlf' – Region: Spain

**Note:** For further information about the process of importing and exporting translation files into the different languages, see section 2.1.9.3.

- **Object to change the temperature scale** [*disabled* / *enabled*]: enables or disables the 1-bit object “[General] Temperature scale”, which permits changing the scale of the temperatures. By receiving one ‘0’ through this object, the scale will switch to Celsius, while after receiving one ‘1’ it will switch to Fahrenheit.

The selected scale applies to any temperatures shown on the screen and takes precedence over the scale corresponding to the locale.

## 2.1.5 SECURITY

---

Any box or page will be given the possibility of **restricted access by password**. Up to **two security levels** can be configured, with the level 2 access password taking priority over the level 1 password, so that any controls page or box can be protected by one or the other, or by none at all.

Buttons that lead to a protected page or box will show a little **lock** icon overlaid on their lower right corner. Figure 9 shows the “enter password” dialog shown to the user when trying to access a protected page.

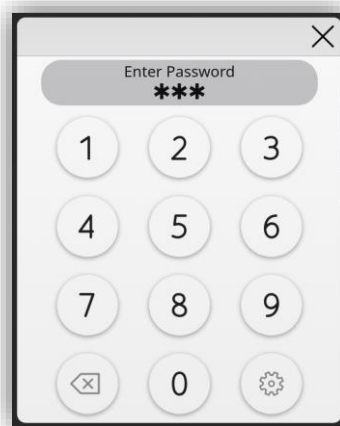

Figure 9. Security pop-up

In case of setting up **two levels**, the first one is assumed to be *enclosed* by the second one. This means that whenever the device asks the user to type password #1 (to enter a certain item); password #2 will also be accepted. On the contrary, password #1 cannot be used instead of password #2. This behaviour permits, therefore, making password #2 available to users with further privileges while password #1 is assigned to users with fewer privileges.

Moreover, when accessing to a protected page, all the boxes and pages with the same or lower access level of the introduced password, are automatically unlocked. It can be set if the elements are relocked after pressing the Home Button.

## ETS PARAMETERISATION

This screen permits selecting how many security levels (one or two) will be available for the configuration of the access to the control pages or the boxes.

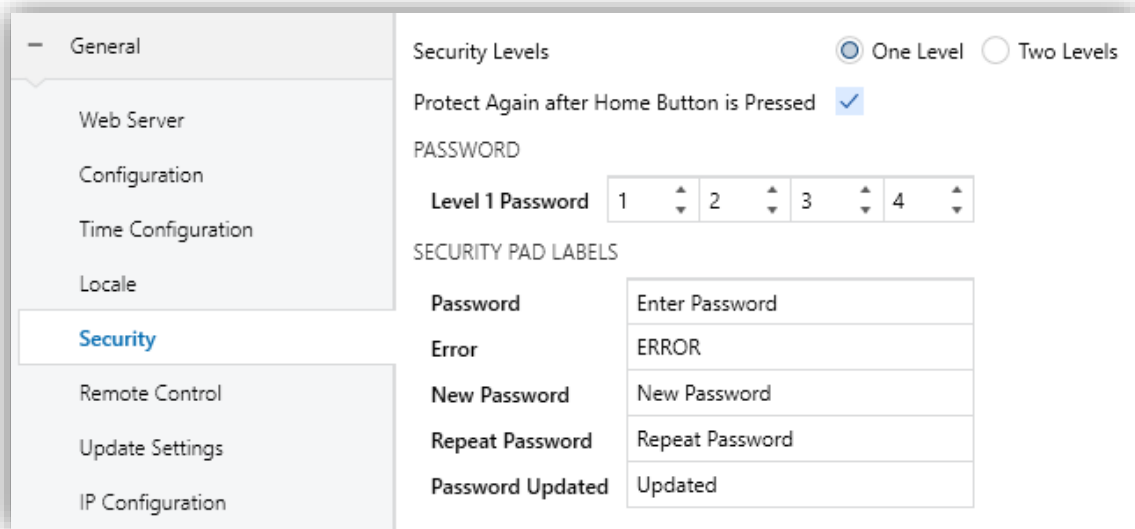

Figure 10. Security

- **Security Levels** [[One Level](#) / [Two Levels](#)]: parameter for selecting whether one or two security levels will be available.

**Note:** with independence of the option selected here, it will be necessary to establish the security level desired for each specific page of controls.

- **Protect Again after Home Button is Pressed** [[disabled](#) / [enabled](#)]: if enabled, the security of the boxes and/or pages will be restored when the Home Button is pressed.
- **Password** [Level 1: [1234](#); Level 2: [5678](#)]: parameter made of four additional textboxes, each of which should contain one of the four consecutive digits [0...9] that will compose the password. In case of enabling two security levels, the Password parameter will show twice, being the first one referred to the password of Level 1, and the second one to the password of Level 2.



Figure 11. Two security levels

**Important:** the password insertion dialog features a specific option (lower right button) that lets the user change, in runtime, the passwords originally set by parameter. After accessing this option and prior to typing the new password, the text box will be set with a blue background and the user will be required to type the corresponding old password (level 1 or level 2). Note that although it will be possible to type password 2 even if the device asks for password 1, the new password typed afterwards will be anyway stored as the new password for level 1.

- **Security Pad Labels:** parameter consisting in six additional textboxes, intended for the customisation of the messages that the device shows (or may show) when the user interacts with the password insertion dialog.
  - **Password 1** [[Enter Password 1](#)]: message shown when the user is required to type in the password for level 1.
  - **Password 2** [[Enter Password 2](#)]: message shown when the user is required to type in the password for level 2.
  - **Error** [[ERROR](#)]: message shown to the user when the typed password is not valid.
  - **New Password** [[New Password](#)]: message shown to ask the user for a new password, during the password change process.
  - **Repeat Password** [[Repeat Password](#)]: message shown when the user is required to re-type the new password.
  - **Password Updated** [[Updated](#)]: message shown to the user as a confirmation of the password change.

## 2.1.6 REMOTE CONTROL

Remote control allows to control the device remotely from a mobile device or a computer with an internet connection. To be able to perform this control, it is necessary to first pair the device, which can be done in different ways (see [ANNEX I. Remote Control via IP](#) for more information).

### ETS PARAMETERISATION

Within this tab the following parameters are displayed:

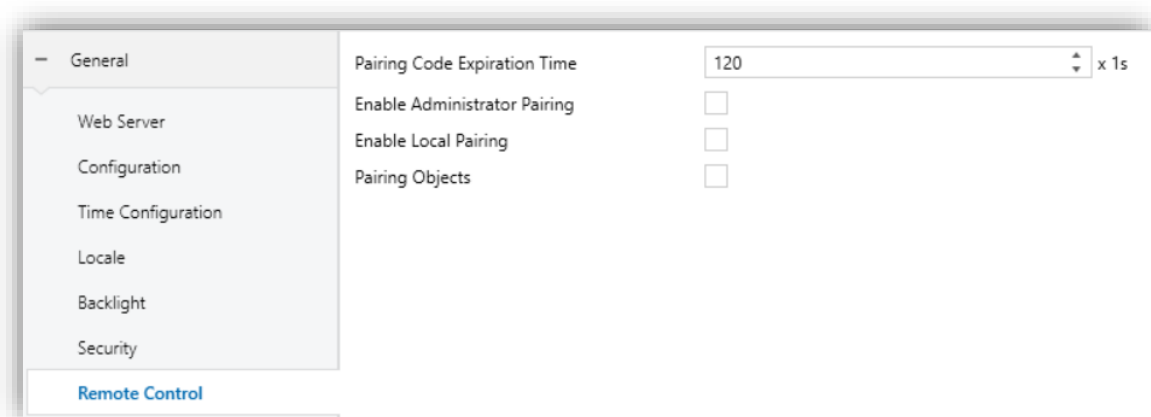

Figure 12. Remote Control tab

- **Pairing Code Expiration Time** [[60](#) ... [120](#) ... [3600](#)]: sets the time that pairing code will be valid.
- **Enable Administrator Pairing** [[disabled](#) / [enabled](#)]: enables the possibility of performing an administrator pairing through Zennio Remote Manager. This pairing is performed using the administrator password without press the pairing button on the display and it can only be deleted from the application.

**Note:** *in order to perform this type of pairing it is necessary to contact the manufacturer to assign administrator permissions to the user account.*

- **Enable Local Pairing** [[disabled](#) / [enabled](#)]: enables the local pairing function from the application. Both devices must be connected to the same network to find the device automatically.

- **Password:** sets the password to be used for local pairing. If this field is empty, the local pairing password will be the default password of the Webserver Tools (only in case the device contains a password sticker).
- **Pairing Objects** [*disabled* / *enabled*]: enables the pairing dedicated objects. For more information see ANNEX I. Remote Control via IP.

## 2.1.7 SCHEDULERS

---

The device offers the possibility to enable up to **30 schedulers**, within which the execution of up to 30 timed sending actions to the KNX bus can be configured.

Timed actions are performed on the **programmable controls** that have been configured in the device:

### ● **1-Button Controls:**

- Switch.
- Scene
- Two Object (Short Press/Long Press<sup>2</sup>).
- Hold & Release.
- Enumeration.
- Constant (Counter / Scaling / Float).

### ● **2-Button Controls:**

- Switch.
- Two Object (Short Press/Long Press<sup>2</sup>).
- Counter.
- Scaling.
- Float.
- Enumeration.
- Shutter.
- Dimmer.

### ● **Climate Specific Controls:**

- Temperature Setpoint control.
- Mode.
- Special modes.
- Fan.

### ● **Other Controls:**

- RGB Control.
- Macro.
- RGBW Control.
- Multimedia

To adjust the scheduler configuration settings, access the configuration panel from any of the boxes that have been parameterised as "scheduler" type (see section 2.2.2.1.5.6).

---

<sup>2</sup> In the case of two-object controls (Short Press/Long Press), the schedulers only take into account the short press value.

From this panel navigation to the rest of the available schedulers will be possible, each of them represented by its corresponding icon configured from ETS.

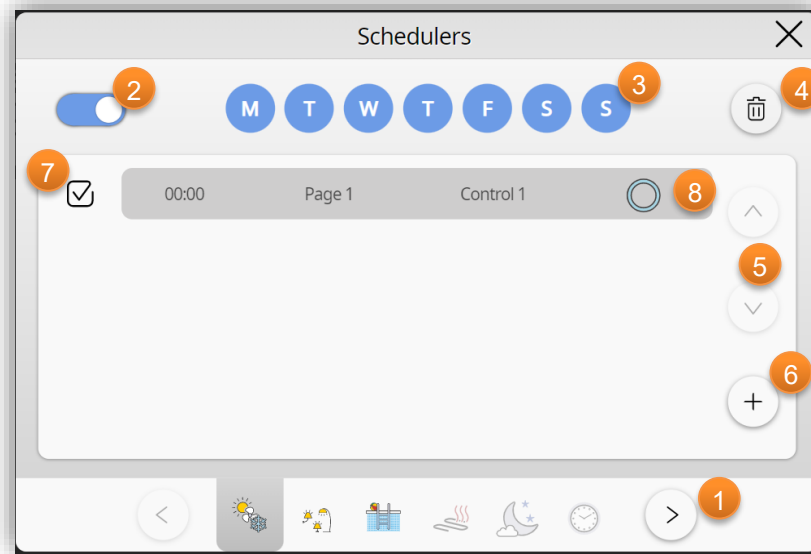

Figure 13. Schedulers panel

The scheduler panel consists of:

- 1 **Navigation area between schedulers** by means of the arrow buttons or by clicking directly on the icon of the scheduler to be displayed.
- 2 **General enable** button to enable/disable the scheduler without deleting the actions.
- 3 **Days of the week** on which the actions configured in the selected scheduler are to be executed.
- 4 Button to **delete all the actions** of the scheduler.
- 5 **Navigation area through the scheduler actions**.
- 6 Button to **add a new action** at the end of the list.
- 7 **Checkbox to deactivate an action individually** without deleting it.

- 8 **Timed action** which will show the **time** of execution, the **page** where the control is located, the **control** to be timed and the **value** to be sent once the configured time has been reached. In case the **Sunrise/sunset** functionality is enabled (see section 2.1.3), a selector shall also be displayed to configure the sending with respect to the time of sunrise or sunset.

The configuration of actions is done by entering edit mode. This happens when a new action is added or when clicking on one of the panel visible actions. Entering edit mode expands the action, showing the buttons to modify each field and a new button to delete the action, as shown in Figure 14.

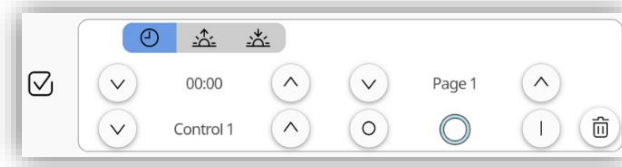

Figure 14. Edit mode for scheduler actions

Saving the configured actions occurs when navigating to another scheduler or closing the panel by clicking outside the editing dialogue.

**Note:** *if there are any protected controls, these can only be timed if the panel is accessed with a security level equal to or higher than that of the control. Otherwise, these actions are hidden. Besides, if any action is configured with a higher security level than the current one, it will be notified with a padlock and it will not be allowed to modify the global actions of the scheduler (**general enabling, days of the week and deleting all actions**).*

Each of the schedulers may be enabled/disabled either from the panel or from the scheduler communication object "[Sx] Scheduler - Enable".

## ETS PARAMETERISATION

After enabling **Schedulers** from "Configuration" screen (see section 2.1.2), a new tab will be incorporated into the tree on the left.

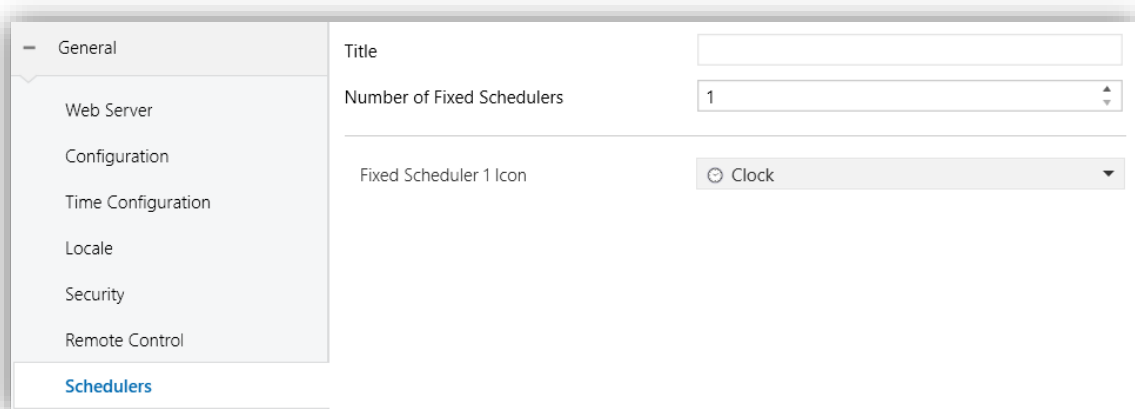

Figure 15. Schedulers tab

- **Title:** text displayed at the top of the general scheduler panel.

- **Number of Fixed Schedulers** [[1...30](#)]: sets the number of schedulers available for setting on the device.
- **Fixed Scheduler n Icon** [[Clock](#)]: selects the icon to be displayed in the navigation area for each scheduler.

## 2.1.8 ENERGY MONITOR

The Energy Monitor control offers the possibility of **displaying energy and power consumption**, both for the house as a whole and for individual devices.

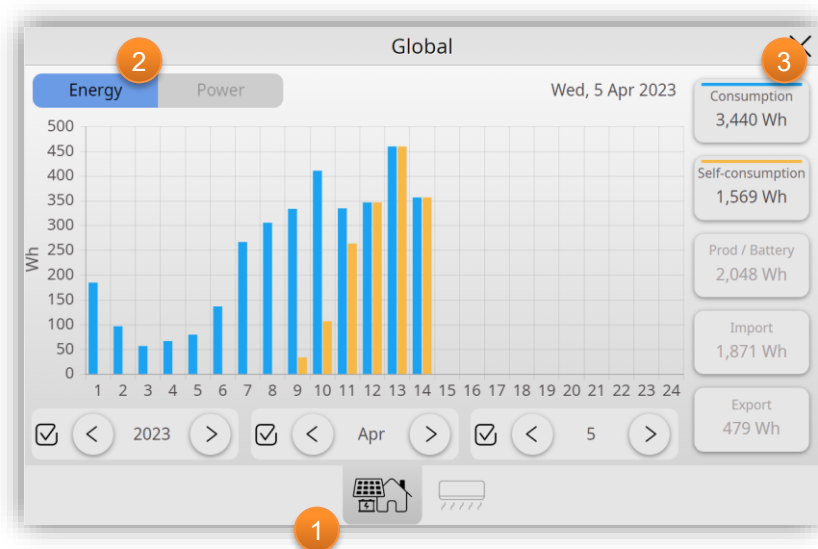

Figure 16. Energy Monitor - Global Tab

The panel of Energy Monitor consist of:

- 1 Navigation area between tabs of:
  - **Global measurements of the house** (consumption, solar production...)
  - **Individual device consumption.** It is possible to enable up to 4 individual consumption tabs with 6 devices each.

Navigation between the different tabs is done by clicking on the icons on the bottom bar of the panel.

## 2 Navigation area between graphs of:

- **Energy:** has a zoom by day, month, year, and the history of the last 10 years. The values are represented with a bar graph, and in the case of the devices tab, the representation can be stacked or not.
- **Power:** has an hour and day zoom, storing the data received for the last 30 days. The values are represented with a step-type graph.
- For further information about graphs navigation see

ANNEX II. Graphs.

## 3 Selectors of magnitudes/devices. Allow to show or hide these values in the graph by clicking on the corresponding box.

The magnitudes shown depend on the house **installation type**:

- **No Solar Panels and No Battery:** in this case there is only one measurement point so only consumption data can be obtained.
- **Solar Panels without Battery / with Battery:** the following values can be displayed in the global tab:
  - **Consumption:** total energy consumed in the house.
  - **Self-consumption:** energy generated that has been consumed in the house.
  - **Production / Battery:** energy generated by the solar installation.
  - **Import:** energy imported from the electricity grid.
  - **Export:** energy exported to the electricity grid.
- **Solar Panels with Battery (Two Inverters):** the same magnitudes are shown as in the case of a single inverter, adding the following magnitudes:
  - **Battery Out:** energy exported from the battery to the system.
  - **Battery In:** energy imported into the battery.
  - **Battery Balance:** difference between the energy imported and exported from the battery.

- **Note:** these 3 magnitudes will be displayed in a single magnitude selector that will function as a list to select what is shown in the graph.

For more information about the configuration of the energy monitor, see [ANNEX III. Energy monitor configuration](#).

## ETS PARAMETERISATION

After enabling **Energy monitor** from “Configuration” screen (see section 2.1.2), a new tab will be incorporated into the tree on the left.

Data	Enable	Text on Display	Measured	Calculated
Consumption	<input checked="" type="checkbox"/>	Consumption	<input checked="" type="checkbox"/>	
Self-consumption	<input type="checkbox"/>	Self-consumption		
Production	<input type="checkbox"/>	Production		
Import	<input type="checkbox"/>	Import		
Export	<input type="checkbox"/>	Export		

Figure 17. Energy monitor tab

- **Energy units** [[Wh \(DPT 13.010\)](#) / [kWh \(DPT 13.013\)](#)]: sets the DPT of the energy objects. Regardless of the option chosen, the monitor will always display values below 1000 Wh in Wh and values above 1000 Wh in kWh.
- **Energy Selector Text** [[Energy](#)]: this text field allows choosing which text will be displayed for energy graph selector.

- **Power units** [[W \(DPT 14.056\)](#) / [kW \(DPT 9.024\)](#)]: sets the DPT of the power objects. Regardless of the option chosen, the monitor will always display values below 1000 W in W and values above 1000 W in kW.
- **Power Selector Text** [[Power](#)]: this text field allows choosing which text will be displayed for power graph selector.
- **Global Measurements Tab** [[disabled](#) / [enabled](#)]: enables the global measurements tab.
  - **Global Tab Title** [[Global](#)]: sets the text displayed at the top of screen of the global measurement tab.
  - **Icon** [[House](#)]: sets the icon of the global measurement tab.
  - **Installation Type** [[No Solar Panels and No Battery](#) / [Solar Panels without Battery](#) / [Solar Panels with Battery](#) / [Solar Panels with Battery \(Two Inverters\)](#)]: In case of choosing an installation with solar panels the following parameter will be displayed:
    - **Is There House Measuring Point? (Point 3)** [[disabled](#) / [enabled](#)]: parameter to indicate whether there is a measuring point in the house such as point 3 in the diagram.
    - **Show Battery Percentage on Graph** [[disabled](#) / [enabled](#)]: enables a battery percentage indicator to be displayed at the top of the graph. The value displayed will be received through the “[EM] Battery Percentage” object.

Below is a table with the different magnitudes that can be enabled (this will depend on the type of installation configured in ETS). In the same table, the text that will appear in the legend is also configured and it is indicated whether the magnitudes are calculated or measured:

- **Consumption:** enables “[EM] Consumed Energy” and “[EM] Consumed Power” objects.
- **Self-consumption:** this data is always calculated, so it has no object associated.
- **Production:** enables “[EM] Produced Energy” and “[EM] Produced Power” objects.

- **Importation and exportation:** enables “[EM] Imported Energy” and “[EM] Exported Energy” objects respectively, while in power data case there is one shared object “[EM] Imported/Exported Power”.
- **Battery Out and In:** enables the objects “[EM] Battery Output Energy” and “[EM] Battery Input Energy” respectively, while for power there is a single shared object “[ME] Battery Input/Output Power”.
- **Battery Balance:** this data is always calculated as the difference between battery energy input and output.

**Note:** *communication objects will only be displayed when the enabled data is marked as measured.*

- **Individual Consumption Tabs** [*disabled* / *enabled*]: enables the individual consumption tabs. In addition, the parameter appears:
  - **Number of tabs** [*1* / ... / *4*]: sets the number of individual consumption tabs.
- **Automatic Read Requests** [*disabled* / *enabled*]: if enabled, the device sends read requests at the end of each hour for all energy objects.
- **Split Imported/Exported Power and Battery In/Out into Two Objects** [*disabled* / *enabled*]: split the imported/exported and Battery in/out power objects into two separate objects.

#### 2.1.8.1 INDIVIDUAL CONSUMPTION N

---

In case of enabling individual consumption tabs, subtabs will appear on the tree of the left with the following parameters:

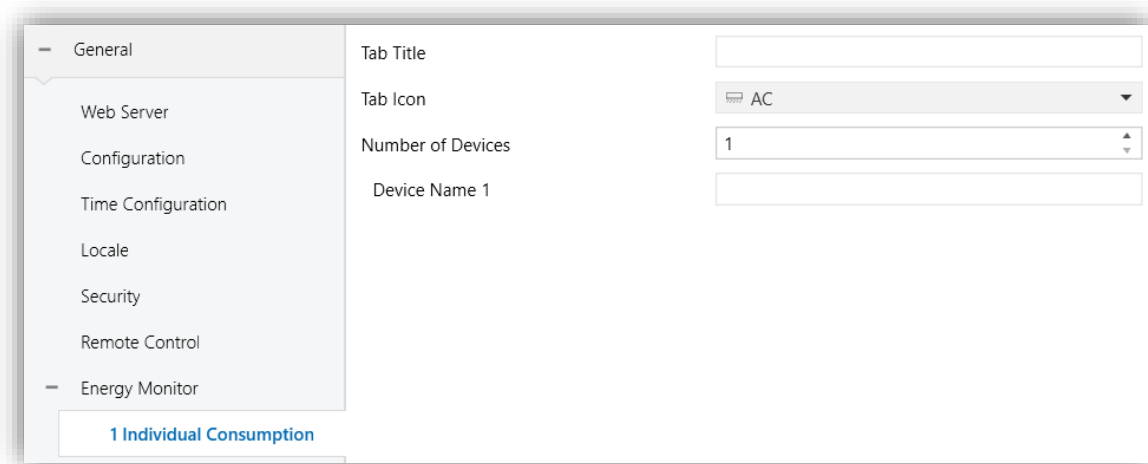

Figure 18. Individual consumption tab

- **Tab title:** defines the individual consumption tab title.
- **Tab Icon [AC]:** sets the icon which will be displayed on the corresponding individual consumption tab.
- **Number of Devices [1 / ... / 6]:** sets the number of devices which will be displayed on an individual consumption tab. The objects "[EM][ICX][DX] Consumed Energy" and "[EM][ICX][DX] Consumed Power" will be added for each enabled device.
- **Device Name N:** text field which allows defining the device name from the N enabled devices.

### 2.1.9 SONOSUPDATE SETTING

---

It is possible upgrading some of the available functions. These functionalities and how they should be updated are described in the following sections.

## ETS PARAMETERISATION

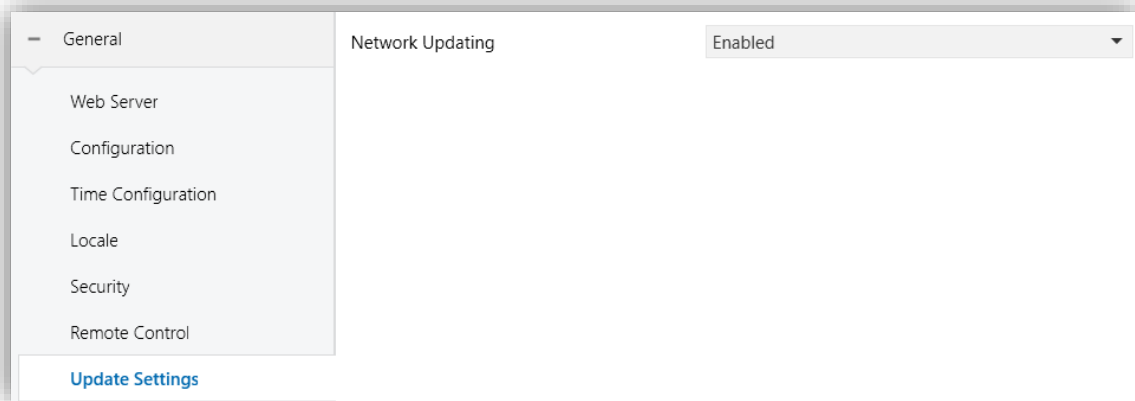

Figure 19. Firmware Update

- **Network Updating:** [*Disabled / Enabled / Enabled (Password Protected)*]: brings the option to restrict the updates via Ethernet to those who can provide the required password to the update tool before the firmware download starts. This password, consisting in four numbers, needs to be set in ETS by the integrator.

**Note:** *reading the specific user manual of the firmware update process available at the Zennio webpage is encouraged, as it contains particular remarks regarding the password protection.*

### 2.1.9.1 FIRMWARE UPDATE

For detailed information about the update process, please refer to the “**Firmware update**” specific document, available at [www.zennio.com](http://www.zennio.com).

#### **Important:**

- *Firmware updates do not re-set the alarm and error logs, nor does it clear the on-screen user configuration.*
- *The firmware version must be greater or equal than program application version on the first two digits.*

### 2.1.9.2 LICENCE SETUP

Some of the functionalities available require the installation of a license for their use. If it is not pre-installed, it will be provided by Zennio in a *.lic* file.

Functionality \ Licence	“Remote”	“Zenvoice”	“All”
Remote control via IP	✔	✘	✔
Voice control	✘	✔	✔

**Table 3.** Functionalities associated with licenses

**Note:** voice control functionality is only available if the device also has remote licence installed.

Within the Remote functionality there are different licences depending on the maximum number of controls allowed. The device includes a default licence for up to 100 controls, which can be expanded through different licences to a maximum of 240 controls.

Licences can be installed through a web server utility. The installation process is described in the manual "**Webserver Tools**", available in the product section in Zennio web portal, [www.zennio.com](http://www.zennio.com).

### 2.1.9.3 IMPORT AND EXPORT TRANSLATIONS

The translations will be saved in \*.xlf files. After a download, the ETS parameterised texts will be the ones in the main language, and it will be overwritten.

Other languages files will have to be generated externally and, afterwards, uploaded to the touchscreen. For this purpose, it will be possible to export and import languages through a web server utility. The process is described in the manual "**Webserver Tools**", available in the product section in Zennio web portal, [www.zennio.com](http://www.zennio.com).

To **import new translations**, the files with must have \*.xlf extensions. The files names should follow the nomenclature "*text\_language-region.xlf*", where "*language*" must be the two letters code that correspond to the language and "*locale*" the two letters code associated to the region.

For example, "*text\_en-GB.xlf*" would be the language corresponding to English and United Kingdom locale.

A generic translation file can also be generated for a language that is not associated with a particular locale. To do this, it is necessary to follow the nomenclature "*text\_language-ZZ.xlf*".

**Important:** *if the language change is done using the **2-byte** object, the translation files must follow the nomenclature “text\_language-ZZ.xlf”. If the **1-byte or 4-byte** objects are used for the language change, the translation files must follow the nomenclature “text\_language-region.xlf”.*

**Notes:**

- *After a download, the \*.xlf file for the main language is overwritten, but not for the other languages.*
- *Translations files should not include the characters ‘<’, ‘>’ or ‘&’. If someone wants to use these characters must use their equivalent valid representation: ‘&lt;’, ‘&gt;’, y ‘&amp;’, respectively.*
- *The characters that can be displayed on the screen correspond to the alphabets supported by the "[Noto](#)" font.*

For texts translations, it is recommended to use a translation management tool such as OLT (Open Language Tool), to facilitate the translation process with \*.xlf files.

#### 2.1.9.4 CUSTOM ICONS

---

It is possible to import **customised icons** for buttons, boxes or indicators. These icons are parameterised from ETS and will appear with the name “**Cx**” (see sections 2.2.1.3 and 2.2.2.1).

It is possible to import custom icons through a web server utility. The process is described in the manual "**Webserver Tools**", available in the product section in Zennio web portal, [www.zennio.com](http://www.zennio.com).

To do this, a folder called “**icons**” must be created, which in turn will have a certain folder structure:

- Custom icons will be differentiated between those generated for the light theme (folder “**light**”) and those generated for the dark theme (folder “**dark**”):

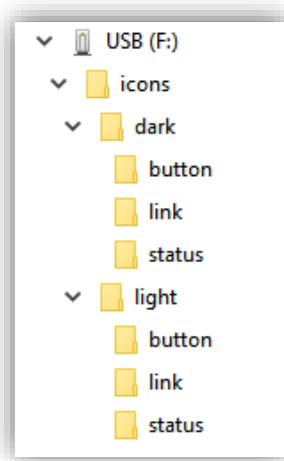

Figure 20. Custom icons (light and dark theme). Root folder structure

This structure will have other folders in which the custom icons will be saved with the name "**custom\_icon\_1.svg**", "**custom\_icon\_2.svg**", etc.:

- **Button:** icons for the boxes buttons (maximum 15 customised icons).
- **Link:** icons for direct link boxes or pages (maximum 40 customised icons).
- **Status:** icons for box indicators (maximum 40 customised icons).

**Notes:**

- *The maximum size of the icons cannot exceed 20KB.*
- *If the name or the format of any of the files is not correct, it will not be imported.*
- *Custom icons do not modify when **Icons type** parameter is set as [Monochromatic]*

## Recommendations to generate customised icons

When designing and generating custom icons, it is recommended to take into account the following indications to ensure their correct display:

- The viewBox of each of the SVG files should be square (aspect ratio 1:1).
- When exporting the icons:
  - Check the “*Convert to outlines*” option in the font options.
  - Set the number of decimals to 3.
  - Check the “*Responsive*” option.

Figure 21 shows an example of the options in *Illustrator*.

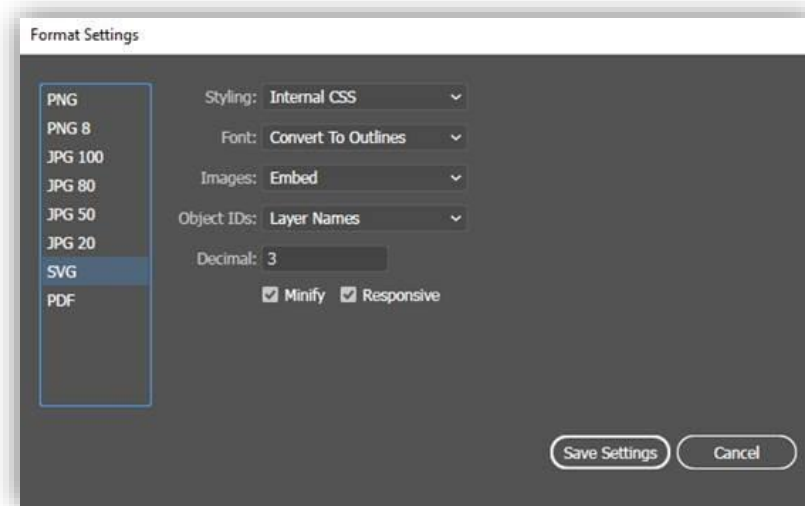

Figure 21. Configuration to export icon in Illustrator

### 2.1.10 IP CONFIGURATION

---

RemoteBOX is able to communicate via Ethernet connection. Such communications will require correct configuration of certain general IP parameters.

## ETS PARAMETERISATION

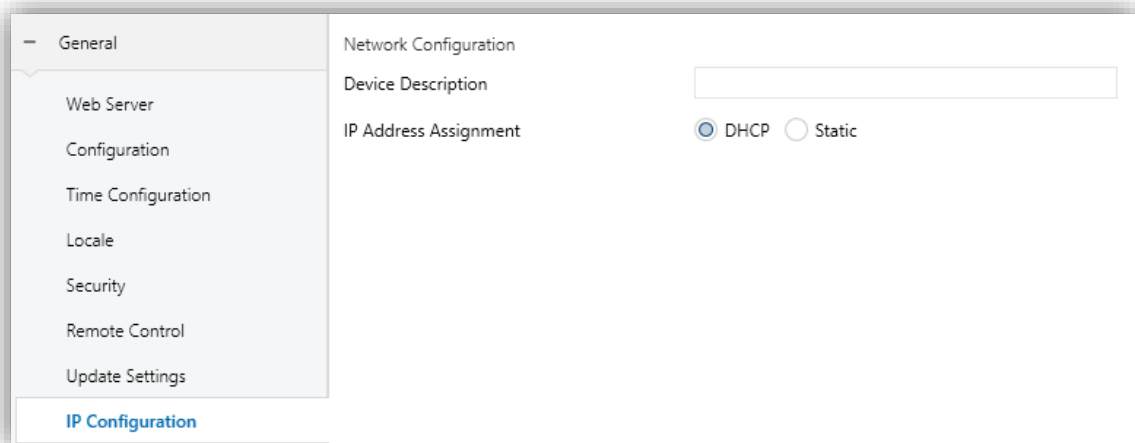
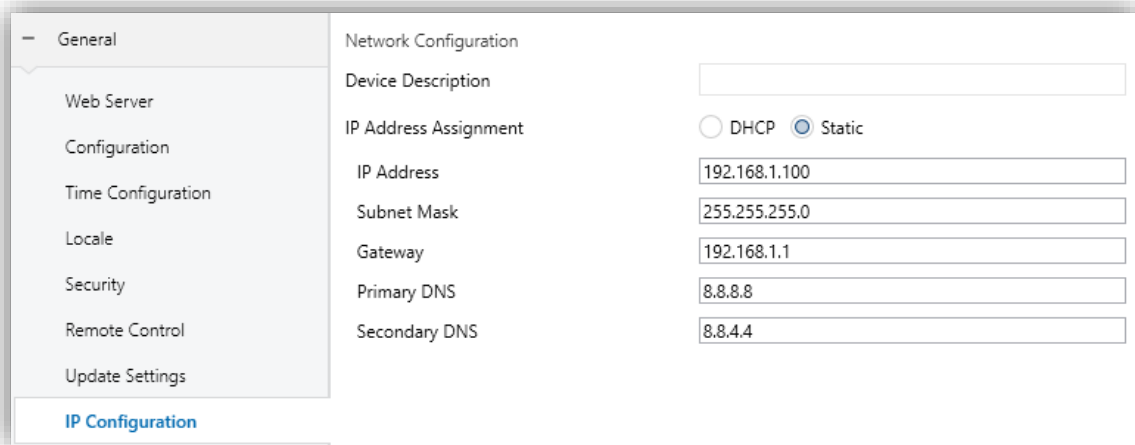

Figure 22. IP Configuration

- **Device Description:** assigns a name to the device.
  
- **IP Address Assignment** [[DHCP](#) / [Static](#)]: selects whether the IP is set by the DHCP protocol or is defined in a static way. If the [Static](#) option is chosen, the following parameters will be displayed:
  - **IP Address** [[192.168.1.100](#)]: is used to uniquely identify the device for functionalities such as Webserver, connection to the device via internet or obtaining the time via NTP. Therefore, it is the IP address that will be indicated to access Webserver Tools.  
  
**Note:** *it is recommended to set this IP address out of the range of addresses assigned by the home router to prevent possible conflicts with the IP address visible to the internet.*
  - **Subnet Mask** [[255.255.255.0](#)]: must match the mask of the network of the device belongs to.
  - **Specify Gateway** [[192.168.1.1](#)]: when enabled permits introduce a gateway.
  - **Primary DNS** [[8.8.8.8](#)]: maintains the authoritative information of a domain name, obtained from its own configuration.
  - **Secondary DNS** [[8.8.4.4](#)]: copies its configuration from the primary.



Network Configuration	
Device Description	<input type="text"/>
IP Address Assignment	<input type="radio"/> DHCP <input checked="" type="radio"/> Static
IP Address	<input type="text" value="192.168.1.100"/>
Subnet Mask	<input type="text" value="255.255.255.0"/>
Gateway	<input type="text" value="192.168.1.1"/>
Primary DNS	<input type="text" value="8.8.8.8"/>
Secondary DNS	<input type="text" value="8.8.4.4"/>

Figure 23. IP Configuration enabled on same network

### 2.1.11 AVANCED

Independent tab for the parameterisation of some advanced functions. These functions are explained next.

#### ETS PARAMETERISATION

After enabling the **Advanced Configuration** from “Configuration” screen (see section 2.1.2), a new tab will be incorporated into the tree on the left.

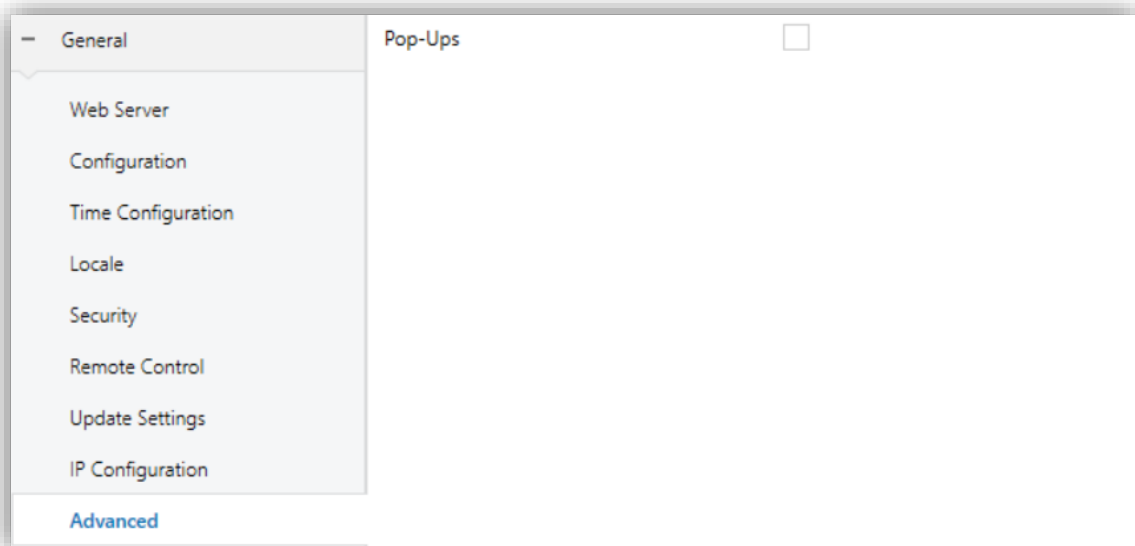

Pop-Ups	
	<input type="checkbox"/>

Figure 24. Advanced Configuration

- **Pop-Ups** [*disabled* / *enabled*]: enables or disables the “Pop-Ups” tab. See section 2.1.11.1 for details.

### 2.1.11.1 POP-UPS

---

This function permits showing the user a **pop-up message** of up to four lines of text on the display, each of which can be object-dependant or set in parameters.

It is possible to enable up to 6 pop-ups, each of which can be launched in 3 different ways: by using a 1-bit object, by using a 1-byte object or by modifying the text of one of the messages. They can also be launched when activating the different states of the control of Room State (see section 2.2.2.1.2.6).

The pop-up can be closed pressing the confirmation button inside it or using the 1-bit or 1-byte objects named above.

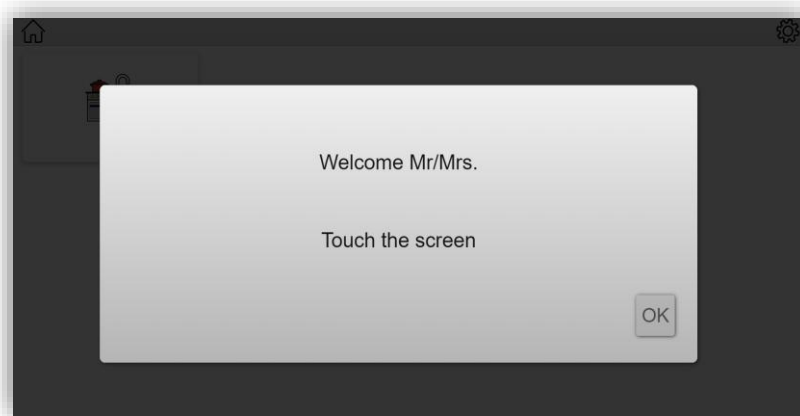

Figure 25. Pop-up

---

### ETS PARAMETERISATION

---

After enabling **Pop-Ups** from “Advanced” screen (see section 2.1.11), a new tab will be incorporated into the tree on the left.

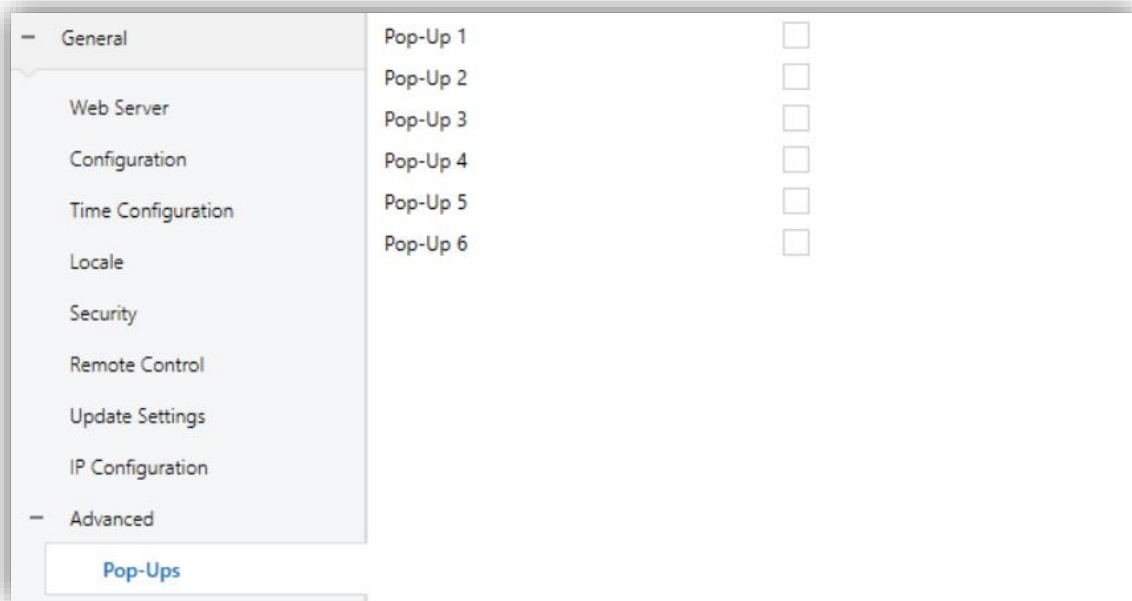

Figure 26. Pop-ups tab

- **Pop-Up n** [*disabled/enabled*]: allows to enable/disable each pop-up. After enabling each pop-up, a new tab will be incorporated into the tree on the left named “Pop-Up n”.

### 2.1.11.1.1 Pop-Up n

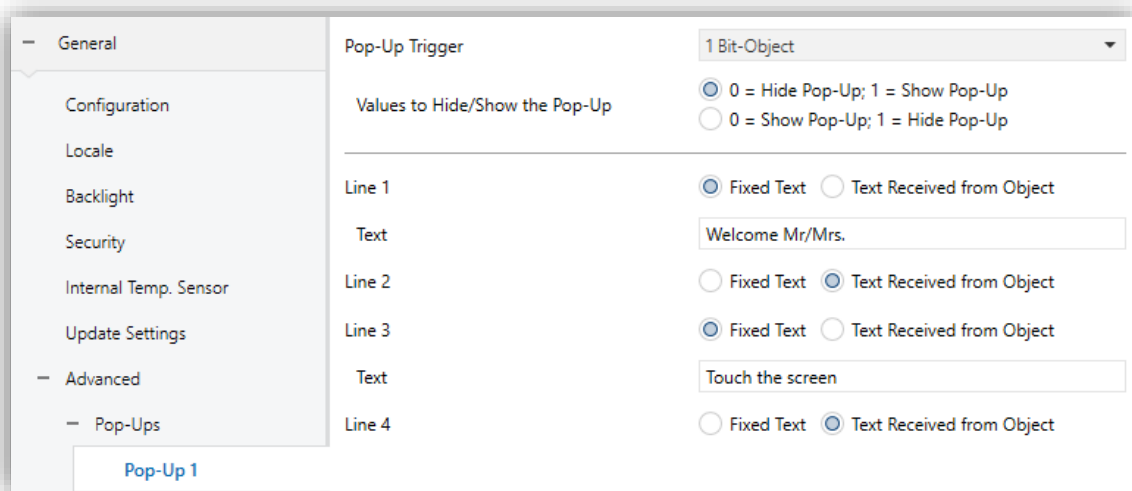

Figure 27. Pop-Up n

- **Pop-Up Trigger**: sets the type of object that is used to show the pop-up message.
  - [*1 Bit Object*]: when this option is selected, the object “[General][Pop-Up n] 1 Bit” appears to launch the pop-up message.

- **Values to Hide/Show the Pop-Up** [*0 = Hide Pop-Up; 1 = Shown Pop-Up / 0 = Shown Pop-Up; 1 = Hide Pop-Up*]: allows to choose the polarity of the 1-bit object to show/hide pop-up.
- [*1 Byte Object*]: allows to show/hide the pop-up through the object “[General][Pop-Up n] 1 Byte”. When selected, the following parameters are displayed:
  - **Object Value to Hide Pop-Up** [*0...255*]: sets the value used to hide the pop-up.
  - **Object Value to Show Pop-Up** [*0...255*]: sets the value used to show the pop-up.
- Note:** *If the value to hide the pop-up is the same as the value to show it, it won't be hidden with any value.*
- [*Changes in 14 Bytes Objects*]: when this option is selected, the pop-up will appear on the screen when a value is received through the objects “[General][Pop-Up n] Line x”.
- **Line [1,4]** [*Fixed Text / Text Received from Object*]: sets whether the corresponding text line will be pre-defined or object-dependent. If “Fixed Text” is selected, the following parameter will appear
  - **Text:** textbox to enter the desired text for the corresponding line.

The 14-byte object “[General][Pop-Up n] Line x” will be shown up to four times per pop-up, depending on how many text lines have been assigned the option “Text Received from Object”.

## 2.2 DISPLAY

### 2.2.1 PAGES

The user interface is organised into **pages** (up to twelve different pages, in addition to the 'Configuration Page'), each of which can be accessed from the Menu page, which (unless the contrary has been parameterised) is automatically shown after the start-up.

The twelve pages are **general purpose**, at the entire disposal of the integrator, who may include up to 20 controls with different functionalities per page. The remaining **Configuration** page is specific purpose, as it is provided for user customisation of the device.

The user interface permanently shows a top bar with the current page name, current time of day and temperature, and if desired, a button that allows the user to return to the "Home" page.

In addition, from the menu page, and provided that it has been enabled, the configuration page can be accessed via a button located in the navigation bar will be possible.



Figure 28. Configuration button

### ETS PARAMETERISATION

<ul style="list-style-type: none"> <li>+ General</li> <li>- Display</li> <li style="background-color: #e0e0e0;">- Pages</li> <li style="background-color: #e0e0e0;">Menu</li> <li>+ Configuration Page</li> <li style="background-color: #e0e0e0;">1 Page</li> <li>+ Controls</li> </ul>	<p>Number of Pages: 1</p> <p>Default Page: Menu</p> <p>Menu Page: <input checked="" type="checkbox"/></p> <p>Home Button in the Navigation Bar: <input checked="" type="checkbox"/></p> <p>Page Linked to the Home Button: Menu</p> <p>Configuration Page: <input checked="" type="checkbox"/></p> <p><b>Pages Enabling</b></p> <p>1 Page</p>
--	---

Figure 29. General pages configuration

The parameters available are:

- **Number of Pages** [1...12]: number of general purpose pages that will be activated on the device. For each page a dedicated ETS tab will be shown for configuration.
- **Default Page** [Menu]: dropdown list that sets the page that will behave as the default page. This page will be the one shown after the inactivity time elapsed.
- **Menu Page** [disabled / enabled]: enables o disables a page with direct access to available general-purpose pages.
- **Home Button in the Navigation Bar** [disabled / enabled]: of enabled, the following parameter will be displayed:
  - **Page Linked to the Home Button** [Menu]: select the page to which the device will navigate when the “Home” button is press.
- **Configuration Page** [disabled / enabled]: if enabled, direct access to the configuration page from the menu page will be allowed.
- **Pages Enabling** [Empty / 1 Page / ... / 12 Page]: set which page, from a list of 12, will be placed in each of the twelve possible boxes on the screen.

### 2.2.1.1 MENU

The user interface may have up to twelve pages of general purpose, each of which can host up to 20 different controls or indicators.

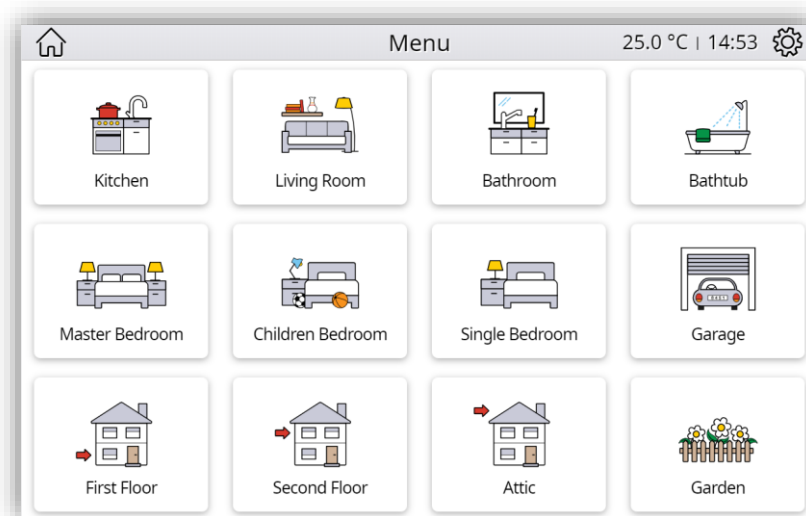

Figure 30. Menu Page

---

## ETS PARAMETERISATION

---

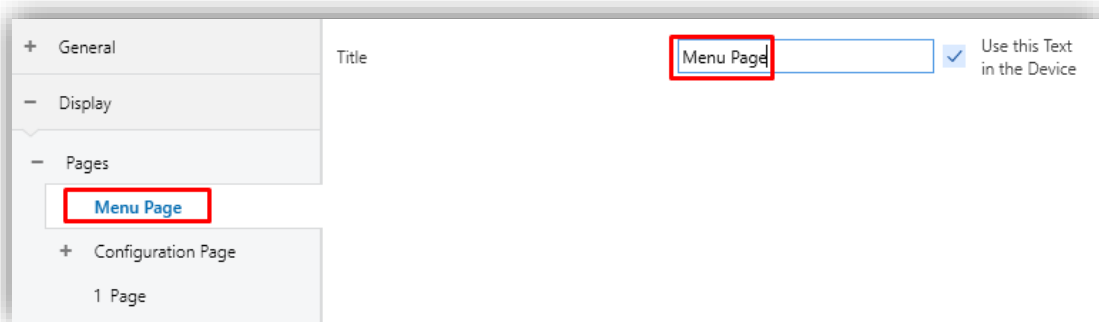

Figure 31. Menu

The parameters available are:

- **Title:** text field that identifies the menu pages. In addition, this field allows changing the name of the tab in ETS left menu, as shown in the Figure 31.
- **Use this Text in the Device** [*disabled / enabled*]: enables the text to be used as the page title in the device.

### 2.2.1.2 CONFIGURATION PAGE

---

The Configuration page lets the user to know or adjust certain technical values about the device, as well as customise the visual and audio adjustments of the user interface.

---

## ETS PARAMETERISATION

---

After enabling the **Configuration Page** from “Pages” screen (see section 2.2.1), a new tab will be incorporated into the tree on the left.

General	Title	<input type="text"/>	<input checked="" type="checkbox"/> Use this Text in the Device
Display	Accessible From	<input checked="" type="radio"/> Menu <input type="radio"/> Any Page	
Pages	Protect	<input checked="" type="radio"/> No <input type="radio"/> Yes	
Menu Page	Device	<input checked="" type="checkbox"/>	
Configuration Page	Label	<input type="text"/>	
1 Page	Protect	<input checked="" type="radio"/> No <input type="radio"/> Yes	
Controls	Object to Show/Hide Box	<input type="checkbox"/>	
	Profile	<input checked="" type="checkbox"/>	
	Label	<input type="text"/>	
	Protect	<input checked="" type="radio"/> No <input type="radio"/> Yes	
	Object to Show/Hide Box	<input type="checkbox"/>	
	Events Log	<input type="checkbox"/>	
	Device Pairing	<input checked="" type="checkbox"/>	
	Label	<input type="text"/>	
	Protect	<input checked="" type="radio"/> No <input type="radio"/> Yes	
	Object to Show/Hide Box	<input type="checkbox"/>	
	Voice Control	<input checked="" type="checkbox"/>	
	Label	<input type="text"/>	
	Protect	<input checked="" type="radio"/> No <input type="radio"/> Yes	
	Object to Show/Hide Box	<input type="checkbox"/>	

Figure 32. Configuration tab

- **Title:** text field that identifies the configuration page. In addition, this field allows changing the name of the tab in ETS left menu, as shown in the Figure 32.
  - **Use this Text in the Device** [*disabled* / *enabled*]: allows the text to be used as the page title in the device.
- **Accessible From** [*Menu* / *Any Page*]: sets whether the access button to the configuration page appears on all pages or only on the menu page.
- **Protect:** sets whether the page will be password-protected or not. Depending on the security levels configured (one or two; see section 2.1.5) this list will contain the following options:
  - **One Level:**
    - [*No* / *Yes*]: sets whether the page is password-protected at level 1 or without a password.

- **Two Levels:**
  - **[No / Level 1 / Level 2]:** sets the level of security to access the configuration page.
- **Time/Date [disabled / enabled]:** if enabled, the date and time of the device can be set directly from the user interface:

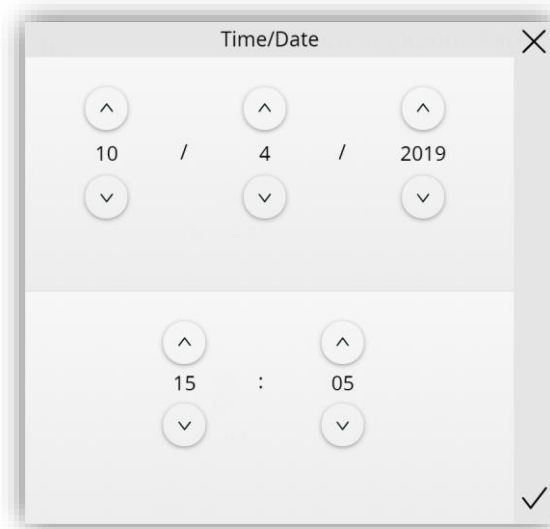

Figure 33. Time and date

- **Device [disabled / enabled]:** enables or disables the “Device” tab in the left menu. For more information, see section 2.2.1.2.1
- **Profile [disabled / enabled]:** enables or disables the “Profile” tab in the left menu. For more information, see section 2.2.1.2.2
- **Event Log [disabled / enabled]:** enables or disables the box that gives access to the log where notifications of the different events (alarms, low battery and heartbeat) that have been enabled will be incorporated in reverse chronological order. For each event, the name, time and date of the trigger and the status will be displayed. For more information, see section 2.2.1.3.1.
- **Device Pairing [enabled] (License required):** button to access to the pairing function, which must be executed with each device desired to control the touchscreen remotely. For more details, please refer to ANNEX I. Remote Control via IP.
- **Voice Control [enabled] (License required):** enable the box to activate or deactivate voice control function. Please refer to the user manual “ZenVoice”

(available in the product section at the Zennio homepage, [www.zennio.com](http://www.zennio.com)) for detailed information about the functionality and the configuration.

Moreover, for all these controls, the following parameters can be configured:

- **Label:** text that will appear to identify the box.
- **Protect** [[No](#) / [Yes](#)] / [[No](#) / [Level 1](#) / [Level 2](#)]: exactly the same as the page protection explained above, but for the boxes.
- **Object to Show/Hide Box** [[disabled](#) / [enabled](#)]: when this option is enabled, a new 1-bit object appears (“**[Config.][Bi] Show/Hide Box**”) that allows hiding / showing the box through the KNX bus.

#### 2.2.1.2.1 Device

The configuration page, if **Device** is enabled, will display a button allowing access to several controls and indicators with device-specific information:

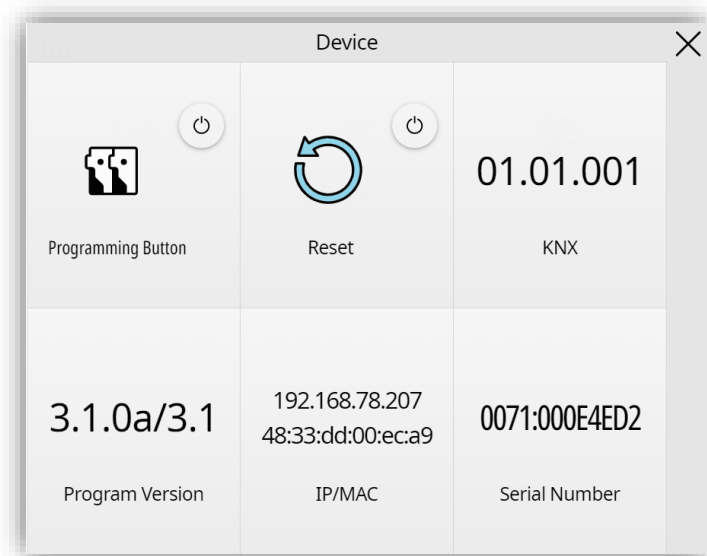

Figure 34. Device

### ETS PARAMETERISATION

After enabling the **Device** from “Configuration Page” screen (see section 2.2.1.2), a new tab will be incorporated into the tree on the left.

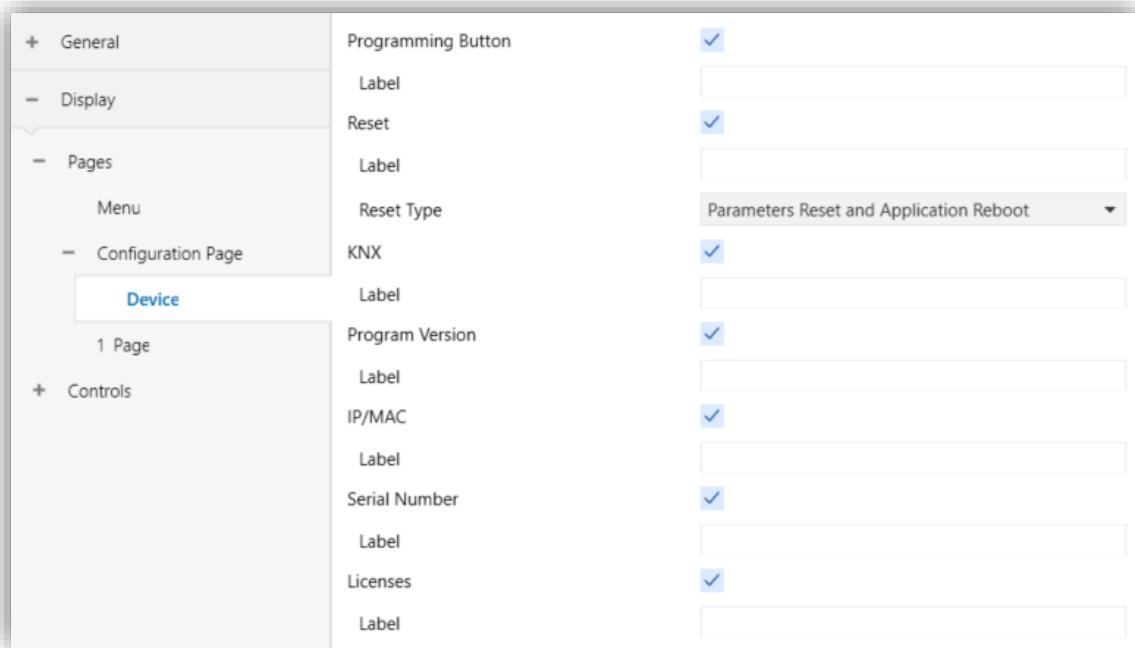

Figure 35. Configuration Page. Device

- **Programming Button** [*disabled* / *enabled*]: control/indicator that shows the status of the Prog./Test LED of the device. In particular, it permits entering/leaving the programming mode as by pressing the actual programming button of the device.
- **Reset** [*disabled* / *enabled*]: enables or disables the box to perform a reset on the device, by pressing more than 3 seconds the button:
  - **Reset Type:**
    - [*Parameters Reset*]: similar to restoring the device to the just-parameterised state.
    - [*Application Reboot*]: simple device reset, with no data loss.
    - [*Parameters Reset and Application Reboot*]: the above two, combined.
- **KNX** [*disabled* / *enabled*]: indicator that shows the individual address of the device.
- **Program Version** [*disabled* / *enabled*]: indicates the downloaded firmware and program version.
- **IP/MAC** [*disabled* / *enabled*]: indicates the IP and MAC direction.
- **Serial number** [*disabled* / *enabled*]: indicates the device serial number.

- **Licenses** [*disabled* / *enabled*]: indicates the licences that are installed on the device. Uninstalled licences will be displayed in light grey.

Moreover, for all these controls, the following parameter can be configured:

- **Label:** text that will appear to identify the box.

### 2.2.1.2.2 Profile

The configuration page, if **Device** is enabled, will display a button to access the visual and sound settings of the device.

#### ETS PARAMETERISATION

After enabling the **Profile** from “Configuration Page” screen (see section 2.2.1.2), a new tab will be incorporated into the tree on the left.

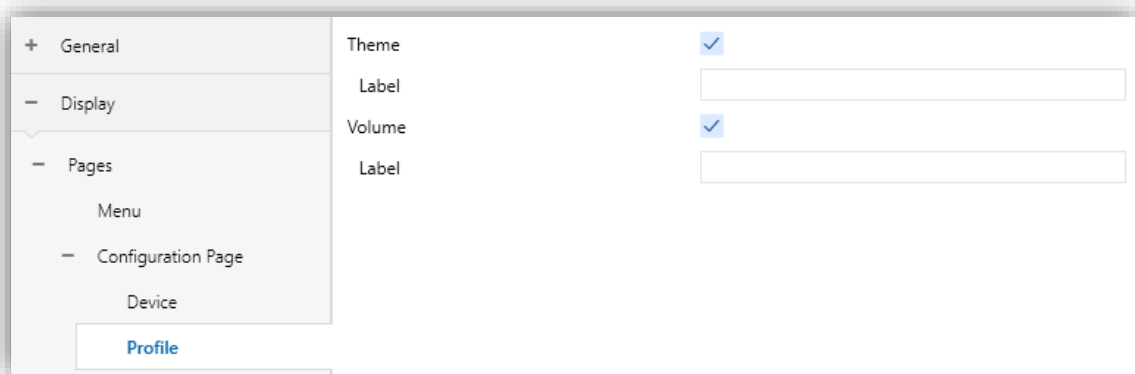

Figure 36. Configuration Page. Profile

- **Theme** [*disabled* / *enabled*]: enables or disables the box for the selection of the theme.
- **Volume** [*disabled* / *enabled*]: box to control the volume of pulsation and sending sound. There are three volume levels in addition to the mute option.

### 2.2.1.3 PAGE N

RemoteBOX has up to twelve general purpose pages that can be enabled from the "Pages" tab. Thus, a new tab called **Page n** will be displayed for each of the  $n$  enabled pages.

## ETS PARAMETERISATION

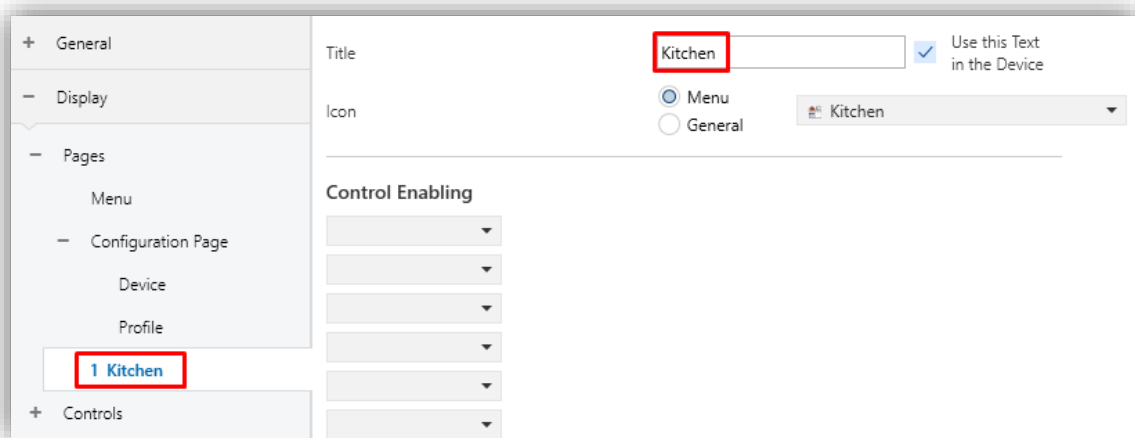

Figure 37. Configuration Page n

This screen contains the following parameters:

- **Title:** text field that identifies each of the enabled pages. In addition, this field allows changing the name of the tab in ETS left menu, as shown in the Figure 37.
  - **Use this Text in the Device** [*disabled / enabled*]: allows the text to be used as the page title in the device.
- **Icon** [*Kitchen*]: sets the icon that will represent the page in the Menu page. It could be selected from two available lists [*Menu / General*].
  - “Menu” is a list of the most common icons that are configured in the main menu.
  - “General” is a list of all available icons. At the end of the list, customised icons, that must have been previously imported, can be selected (see section 2.1.9.4).

**Note:** a list with all icons available can be found in document “Icon list”, available at [www.zennio.com](http://www.zennio.com).

- **Control Enabling** [*Nothing / Control 1...Control 240*]: enables selecting which control, from a list of 240 controls, will be placed in each of the twelve possible boxes on the screen.
- **Protect:** sets whether the page will be password-protected or not. Depending on the security levels configured (one or two; see section 2.1.5) this list will contain the following options:

- **One Level:**
  - [\[No / Yes\]](#): sets whether the page is password-protected at level 1 or without a password.
- **Two Levels:**
  - [\[No / Level 1 / Level 2\]](#): sets the level of security to access the page.
- **Objects to Show/Hide Box** [\[disabled / enabled\]](#): enables or disables a 1-bit object for each enabled box in which a control has been configured (“**[Pn][Bi] Show/Hide Box**”) to show or hide the corresponding box.

### 2.2.1.3.1 Events Log

The event log page allows the user to monitor and confirm up to 70 different events, including alarms, low battery, and heartbeat events.

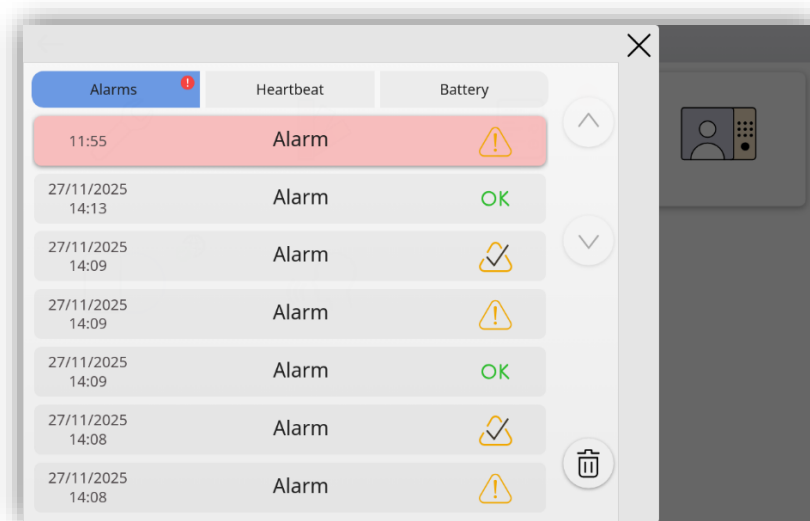









Figure 38. Events Log

There are up to three tabs within the log, each one for a different type of event. The tabs will show the history of each of the events that have occurred, listing them in order from the most recent to the oldest.

At the top of each tab, alert events that have not been confirmed or deactivated will be displayed. Alarm events can be confirmed by clicking on the event. At the bottom, there is a button to delete the entire log.

In the case of alarms, these can be configured as a general control (see section 2.2.2.1.5.4) or within this ‘Event log’ tab. In both cases, the entire history of the alarm statuses on the screen can be viewed in this log.

When any event configured in this log is activated, a warning icon will be displayed and the log will open automatically so that the event can be confirmed.

Alarm status	Icon	Battery	Icon	Heartbeat	Icon
Alarm active		Battery alarm deactivated		Heartbeat received	
Alarm finished, but not confirmed		Battery alarm activated		Heartbeat not received	
Alarm confirmed, but no finished					
Alarm confirmed and finished					

### ETS PARAMETERISATION

After enabling **Events Log** from the “Configuration Page” tab (see section 2.2.1.2), a new tab with the same name is added to the tree on the left with the following parameters:

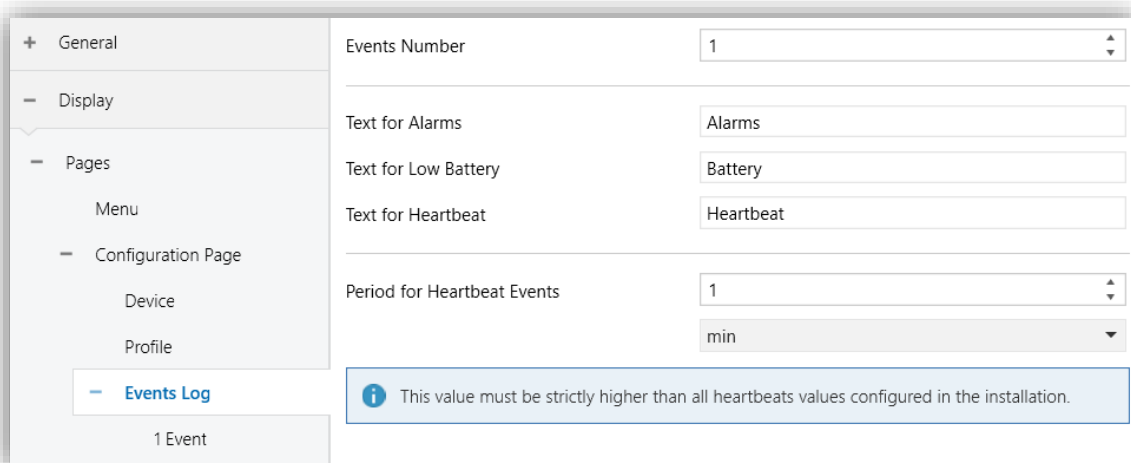

Figure 39. Configuration Page - Events Log

- **Events Number** [1 ... 70]: sets the number of events enabled on the device. A new tab will be displayed for each enabled event (see section 2.2.1.3.1.1).
- **Text for Alarms** [Alarms]: title of the alarms tab.
- **Text for Low Battery** [Battery]: title of the low battery tab.
- **Text for Heartbeat** [Heartbeat]: title of the heartbeat tab.
- **Period for Heartbeat Events** [0 ... 1 ... 65535] [s / min / h]: period to wait to receive the Heartbeat from the devices. The value configured in this parameter must be greater than the heartbeat of the devices to be monitored.

### 2.2.1.3.1.1 N Event

The following parameters will be displayed within the event tab:

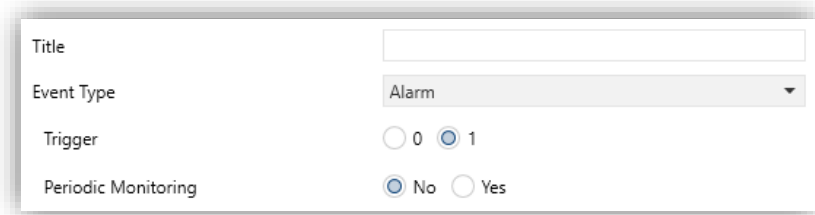

Figure 40. "N Event" tab

- **Title:** name of the event to be displayed in the log.
- **Event Type** [[Alarm](#) / [Low Battery](#) / [Heartbeat](#)]: defines the type of event to be monitored. Depending on the selected event, the following objects will be available:
  - **[Alarm](#):** “[Evi] Alarm - Trigger” to receive the alarm activation and deactivation event and “[Evi] Alarm - Confirmation” to send the confirmation or to receive it if it is confirmed externally.
  - **[Low Battery](#):** “[Evi] Low battery” to receive low battery alarm activation and deactivation.
  - **[Heartbeat](#):** “[Evi] Heartbeat” to receive periodic heartbeat transmissions. If the configured time elapses without receiving a heartbeat, the alarm will be activated.

If the alarm event type is selected, the following parameters will be displayed:

- **Trigger** [[0](#) / [1](#)]: defines the alarm trigger value.
- **Periodic Monitoring** [[No](#) / [Yes](#)]: enables or disables the periodic monitoring function. If enabled, the following parameter appears:
  - **Cycle Time** [[30...65535](#)] [s] [[1...255](#)] [[min/h](#)]: defines the maximum time that may elapse without receiving the non-alarm value before the screen switches to alarm mode.

## 2.2.2 CONTROLS

User interface can have up to 240 different controls placed on 12 pages. Each of this controls will be configured independently and placed in the desire box of the page (see section 2.2.1.3).

Within the controls tab, sub-tabs with groupings of up to 15 controls each are displayed to do parameterization easier.

### ETS PARAMETERISATION

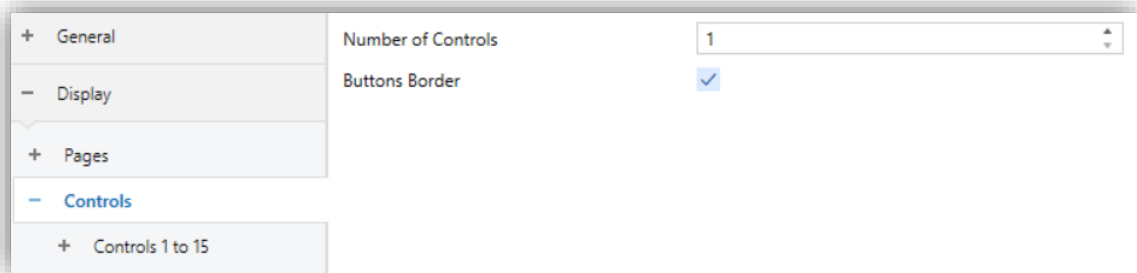

Figure 41. Controls configuration

- **Number of Controls** [1...240]: selects the number of controls that will become available. For each of them a new ETS tab will be shown.
- **Buttons Border** [disabled / enabled]: sets whether the buttons will have an outline or if only the button icon is displayed.

### 2.2.2.1 CONTROL *i*

This screen contains the following parameters common to all type of boxes:

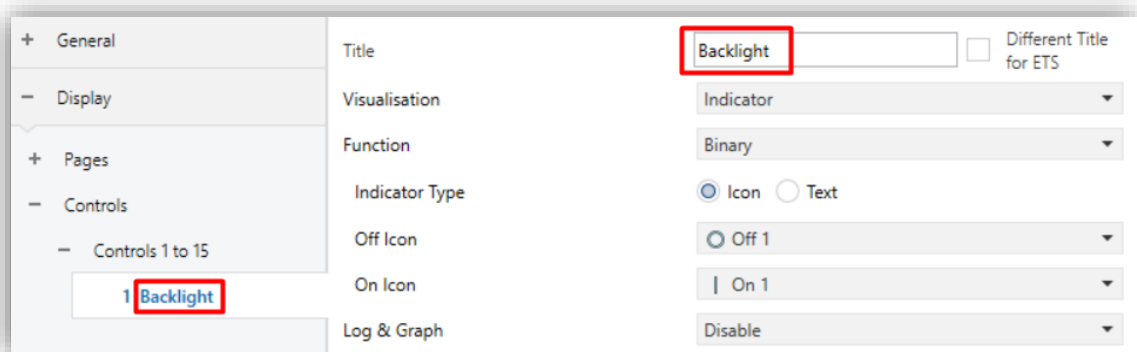

Figure 42. Control *i*

- **Title:** text field that identifies each of the enabled controls and their communication objects, which are designated with the prefix “[Ci][Title]”.

In addition, this field allows changing the name of the tab in ETS left menu, as shown in the Figure 42.

- **Different Title for ETS** [*disabled / enabled*]: allows to specify a different title to be displayed on the device and in ETS.
- **Visualization:** box format. The available box formats are:
    - [*Indicator*]: the box will work as a status indicator.
    - [*1-Button Control*]: the box will work as a one-button control.
    - [*2-Button Control*]: the box will work not only as a status indicator, but also as a two-button control.
    - [*Climate Control*]: the box will act as a climate indicator and a climate control.
    - [*Other*]: the box will implement some other special functionality.
  - **Function:** depending on the “Visualization” type selected, the parameters below will change. The following sections explain the available parameters depending on the visualization type selected.
  - **Slider** [*disabled / enabled*]: sets whether control is via buttons or via a slider. The following is a list of 2-button controls where this option exists:
    - Scaling
    - Dimmer
    - Shutter
    - Temperature Setpoint control

- **Minimum Increment:** step value that the slider will have.

**Note:** in some cases, like shutters or lighting, the control objects may vary, having precise control objects when the control has been configured as a slider.

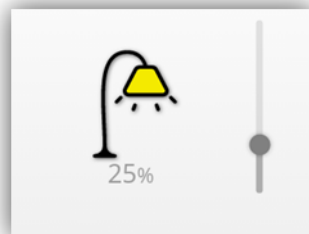

Figure 43. Slider Control

- **Icon and/or Button:** drop-down list with the available icons to show in the indicator(s) and/or button(s) of the box. At the end of the list, the custom icons

("Cx") that must have been previously imported, can be selected (see section 2.1.9.4).

**Note:** a list with all icons available can be found in document "Icon list", available at [www.zennio.com](http://www.zennio.com).

**Log & Graph** [[Disable](#) / [Record Log](#) / [Record Log and Show Graph](#)]: sets if received data through the indicator object will be recorded and if the graph will be displayed. See ANNEX II. Graphs for more information.

- If [Record Log and Show Graph](#) is enabled, the following parameters will be displayed:
  - **Show Hour Zoom** [[disabled](#) / [enabled](#)]: sets whether the hour zoom is enabled on the control graph.
  - **Graph Type** [[Curve](#) / [Straight](#) / [Step](#)]: graph types available for the control. The options for this parameter will depend on the type of control chosen and will only be displayed for non-binary types.
  - **Polarity** [[0 = Low Level; 1 = High Level](#) / [0 = High Level; 1 = Low Level](#)]: sets which is the high level and which is the low level depending on the value received. This parameter will only be displayed on binary type controls.
- **Protect:** sets whether the box will be password-protected or not. Depending on the security levels configured (one or two; see section 2.1.5) this list will contain the following options:
  - **One Level:**
    - [[No](#) / [Yes](#)]: sets whether the control is password-protected at level 1 or without a password.
  - **Two Levels:**
    - [[No](#) / [Level 1](#) / [Level 2](#)]: sets the level of security to operate on the control.

**Note:** neither indicators nor change-scale buttons can be protected.

### 2.2.2.1.1 INDICATORS

---

Controls designed for displaying statuses, showing a numeric or text value, or displaying an icon that represents the current value of a communication object.

### 2.2.2.1.1.1 Binary

When this function is assigned to a control, the “[Ci] Binary Indicator” communication object become available, as well as following parameters:

Visualization	Indicator
Function	Binary
Indicator Type	<input checked="" type="radio"/> Icon <input type="radio"/> Text
Off Icon	Off
On Icon	On

Figure 44. Indicator - Binary

- **Indicator Type** [*Icon* / *Text*]: allows selecting whether the status represented by each indicator value will be text type or icon type.

### 2.2.2.1.1.2 Enumeration

The box will behave analogously to the case of the **Binary Indicator** however, it will be possible to distinguish up to 6 states.

When this function is assigned to a control, a 1-byte communication object, “[Ci] Enumeration Indicator”, will become available as well as a series of parameters:

Visualization	Indicator
Function	Enumeration
Number of Values	2
Indicator Type	<input checked="" type="radio"/> Icon <input type="radio"/> Text
Value 1	0
Icon 1	No Icon
Value 2	1
Icon 2	No Icon

Figure 45. Indicator - Enumeration

- **Number of Value** [*1...2...6*]: sets the number of states in the enumerated list. For every distinguished state, the parameter **Value** [*0...255*] will become available together with the corresponding indicator.
- **Indicator Type** [*Icon* / *Text*]: enables to select whether the status indicator which each value is represented will be text type or icon type. As many drop-down lists

of icons or text boxes will be displayed as states have been enabled in the previous parameter.

### 2.2.2.1.1.3 Numerical Indicators

Indicators configured as “Integer”, “Percentage”, “Float”, “Temperature” and “Cost” are numerical type indicators that show the value of the corresponding communication object, enabled when that control is assigned to a box.

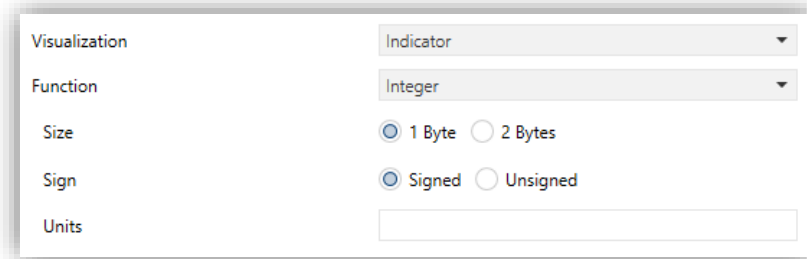

Figure 46. Indicator - Numerical

The range of values allowed for each type and the name of the corresponding object are included in the following table.

Function	Size	Sign	Range	Related Object
<u>Integer</u>	<a href="#">1 Byte</a>	<u>Unsigned</u>	0 – 255	[Ci] Integer - 1-Byte Unsigned Status
		<u>Signed</u>	-128 – 127	[Ci] Integer - 1-Byte Signed Status
	<a href="#">2 Bytes</a>	<u>Unsigned</u>	0 – 65535	[Ci] Integer - 2-Byte Unsigned Status
		<u>Signed</u>	-32768 – 32767	[Ci] Integer - 2-Byte Signed Status
	<a href="#">4 Bytes</a>	<u>Unsigned</u>	0 – 4294967295	[Ci] Integer - 4-Byte Unsigned Status
		<u>Signed</u>	-2147483648 – 2147483647	[Ci] Integer - 4-Byte Signed Status
<u>Percentage</u>	<a href="#">1 Byte</a>		0 – 100	[Ci] Percentage - Status
<u>Float</u>	<a href="#">2 Bytes</a>		-671088.64 – 670433.28	[Ci] Float - 2-Byte Float Status
	<a href="#">4 Bytes</a>		-3,403x10 <sup>38</sup> – 3,403x10 <sup>38</sup>	[Ci] Float - 4-Byte Float Status
<u>Temperature</u>	<a href="#">2 Bytes</a>	<u>Float</u>	-99 – 199	[Ci] Temperature - Status
<u>Cost</u>	<a href="#">1 Byte</a>	<u>Unsigned</u>	0 – 255	[Ci] Cost - 1-Byte Unsigned Int Status
		<u>Signed</u>	-128 – 127	[Ci] Cost - 1-Byte Signed Int Status
	<a href="#">2 Bytes</a>	<u>Unsigned</u>	0 – 65535	[Ci] Cost - 2-Byte Unsigned Int Status
		<u>Signed</u>	-32768 – 32767	[Ci] Cost - 2-Byte Signed Int Status
	<a href="#">2 Bytes</a>	<u>Float</u>	-671088.64 – 670433.28	[Ci] Cost - 2-Byte Float Status

Table 4. Numerical indicators

- **Decimal Places** [0 / 1 / 2]: if the control is set as float, this parameter define the number of decimal displayed in the box.
- **Units**: permits specifying the measuring units of the displayed value.

**Notes:**

- For percentage indicator, the symbol % always will be displayed as unit.
- The temperature indicator will be shown in °C or °F depending on the active locale (see section 2.1.3). In addition, the following parameters will be available for this control type:
  - **Button to Change between °C and °F** [*disabled / enabled*]: enables a control that allows the temperature scale to be changed from the box itself:

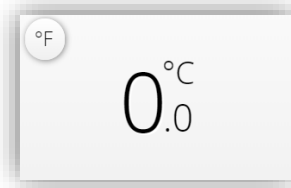

Figure 47. Indicator - Temperature (box)

- **Include Plus Sign before Positive Numbers** [*disabled / enabled*]: shows the '+' sign before positive temperature values.
- For cost indicator, choosing as a unit the currency associated with it, from a list of available ones, will be mandatory. This will be placed before or after the indicator, according to the active locale (see section 2.1.3).

#### 2.2.2.1.1.4 Text

The box will show the text received through the communication object “[Ci] Text - Status”.

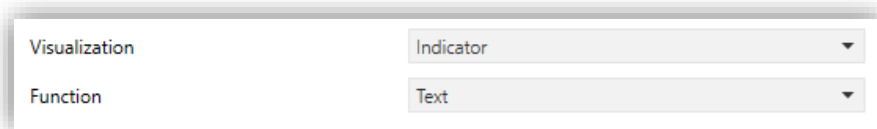

Figure 48. Indicator - Text

### 2.2.2.1.2 1-BUTTON CONTROL

The box configured with this control type will have a button (at the top right or throughout the box, see section 2.2.2) and a state indicator. In addition, through **Function** parameter, it will be possible to select the specific function that the control will perform.



Figure 49. 1-Button Control

#### 2.2.2.1.2.1 Switch

The button of the box will react to user presses by sending a binary value to the bus through the “[Ci] Switch – Control: ‘0/1’” object. In addition, this control will have associated a dedicated object for the box indicator (“[Ci] Switch - Status”), which is automatically updated after the control order is sent and can also receive values from the bus.

Visualization	1-Button Control
Function	Switch
Action	Send 0
Indicator Type	<input checked="" type="radio"/> Icon <input type="radio"/> Text
Off Icon	Off
On Icon	On
Button	<input checked="" type="radio"/> On/Off

Figure 50. 1-Button Control - Switch

- **Action** [[Send 0](#) / [Send 1](#) / [Toggle 0/1](#)]: specifies what value will be sent to the bus after pressing the control button.
- **Indicator Type** [[Icon](#) / [Text](#)]: allows selecting whether the status represented by each indicator value will be text type or icon type.

### 2.2.2.1.2.2 Two Objects (Short Press/Long Press)

The button in the box will react differently to a short press and to a long press, setting a time threshold to distinguish both types of press by parameter.

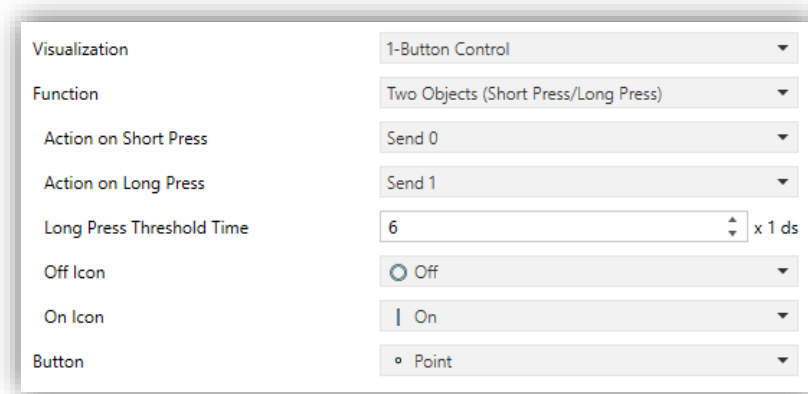

Figure 51. 1-Button Control - Two Objects

- **Action on Short / Long Press** [Send 0 / Send 1 / Toggle 0/1 / Send 1-Byte Unsigned Integer Value]: sets what value will be sent to the bus before which events.

When the option “Send 1-Byte Unsigned Integer Value” is selected, the value indicated in **Value** [0...255] parameter will be sent.

Different objects are used to send values for short and long pulsations: “[Ci] Two objects - Short Press Control” and “[Ci] Two objects - Long Press Control”, respectively.

If the option chosen is “Send 0” or “Send 1”, the object “[Ci] Two objects – Switch Status” will appear for the box indicator, which is automatically updated after the control order is sent and when values are received from the bus.

- **Long Press Threshold Time** [4...6...50] [ds]: sets the minimum time the user should hold the button in order to consider it a long press.

### 2.2.2.1.2.3 Hold & Release

This control function allows the user to configure sending a binary value on pressing and a different binary value on releasing the button. In addition, this control will have associated a dedicated object for the indicator (“[Ci] Hold & Release - Status”), which is automatically updated after the control order is sent and when values are received from the bus.

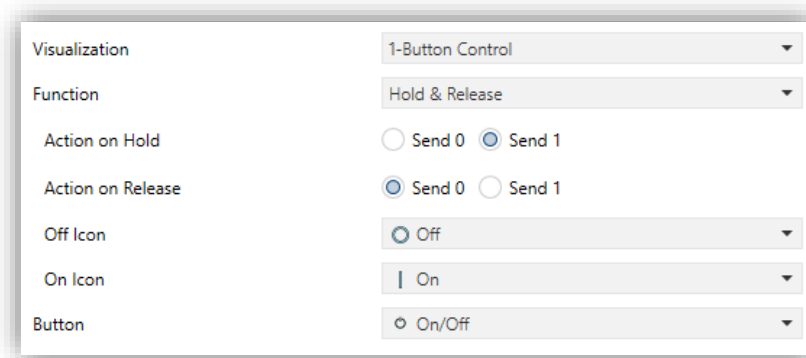

Visualization	1-Button Control
Function	Hold & Release
Action on Hold	<input type="radio"/> Send 0 <input checked="" type="radio"/> Send 1
Action on Release	<input checked="" type="radio"/> Send 0 <input type="radio"/> Send 1
Off Icon	<input checked="" type="radio"/> Off
On Icon	<input checked="" type="radio"/> On
Button	<input checked="" type="radio"/> On/Off

Figure 52. 1-Button Control - Hold & Release

- **Action on Hold / Release** [*Send 0 / Send 1*]: permits setting what value will be sent to the bus through the object "[Ci] Hold & Release - Switch Control", and before which event.

#### 2.2.2.1.2.4 Scene

When this function is assigned to a control, the box button will react to the different pulses by sending a certain scene value.

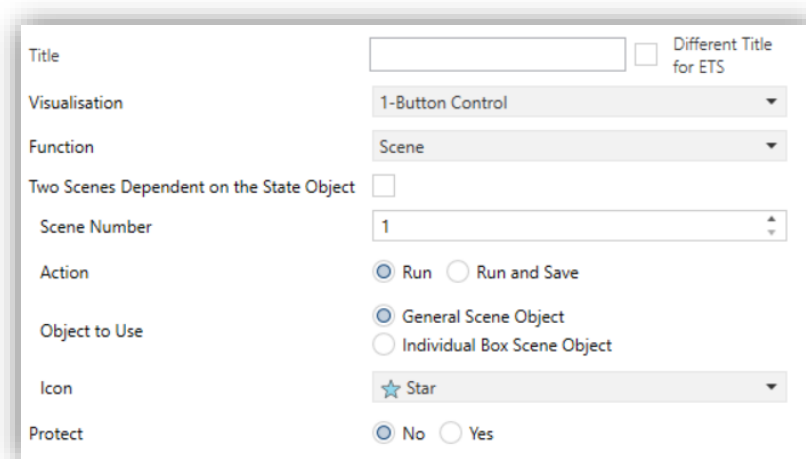

Title	<input type="text"/>	<input type="checkbox"/> Different Title for ETS
Visualisation	1-Button Control	
Function	Scene	
Two Scenes Dependent on the State Object	<input type="checkbox"/>	
Scene Number	1	
Action	<input checked="" type="radio"/> Run <input type="radio"/> Run and Save	
Object to Use	<input checked="" type="radio"/> General Scene Object <input type="radio"/> Individual Box Scene Object	
Icon	★ Star	
Protect	<input checked="" type="radio"/> No <input type="radio"/> Yes	

Figure 53. 1-Button Control - Scene

- **Two Scenes Dependent on the State Object** [*disabled / enabled*]: this parameter sends a different scene when the control is pressed, depending on the status of the "[Ci] Scene Selector" object. If enabled, the following parameters will be displayed twice, once for the **First Scene** and once for the **Second Scene**.
  - **Scene Number** [*1...64*]: scene value to be sent.
  - **Action** [*Run / Run and Save*]: sets whether the device will only send scene execution orders (after a short press) or if it will be possible, to send scene save orders (after a long press).

- **Object to Use** [[General Scene Object](#) / [Individual Box Scene Object](#)]: specifies whether the scene value will be sent through the object "[General Scenes: Send]" or through the individual object "[Ci] Scene – Send Scene Control".

### 2.2.2.1.2.5 Constant Numerical Controls

When the functions “Counter Constant”, “Scaling Constant” or “Float Constant” is assigned to a control, the button in the box will react to user presses by sending a certain numerical value. This numerical value will depend on the constant control type selected to the box.

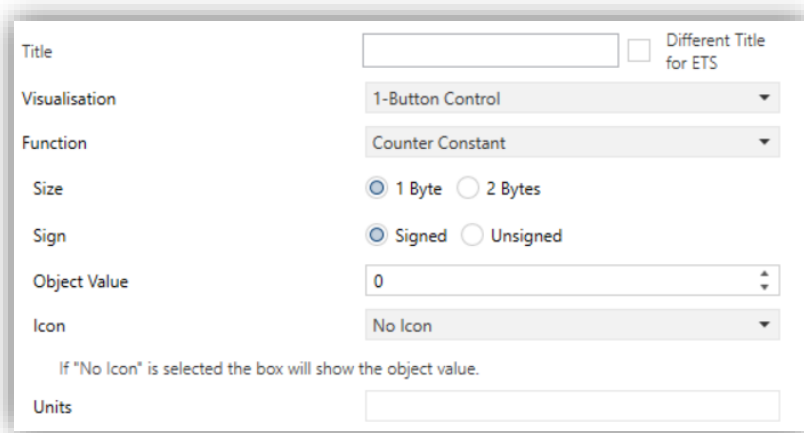

Figure 54. 1-Button Control – Constant Numerical

Table 5 shows the permitted value range and the name of the object through which the values are sent to the bus.

Function	Size	Sign	Range	Related Object
<i>Integer</i>	<a href="#">1 Byte</a>	<i>Unsigned</i>	[0...255]	[Ci] Integer - 1-Byte Unsigned Control
		<i>Signed</i>	[-128...0...127]	[Ci] Integer - 1-Byte Signed Control
	<a href="#">2 Bytes</a>	<i>Unsigned</i>	[0...65535]	[Ci] Integer - 2-Byte Unsigned Control
		<i>Signed</i>	[-32768...32767]	[Ci] Integer - 2-Byte Signed Control
<i>Scaling</i>	<a href="#">1 Byte</a>		[0...100]	[Ci] Percentage - Control
<i>Float</i>	<a href="#">2 Bytes</a>		[-671088.64...0...670433.28]	[Ci] Float – 2-Byte Control

Table 5. Numerical constant controls

- **Decimal Places** [[0](#) / [1](#) / [2](#)]: if the control is set as float, this parameter define the number of decimal places displayed in the box.

- **Units:** permits specifying the measuring units of the displayed value. For percentage indicators, the symbol % always will be displayed as unit.

#### 2.2.2.1.2.6 Room State

Configuring with this function the box, controlling the states of the room will be possible, as well as show the associated pop-up. Thus, pressing the button in the box will cause the room status to switch between *normal* and *Do Not Disturb* or *Make Up Room*.

Visualization	1-Button Control
Function	Room State
State	<input checked="" type="radio"/> Make Up Room <input type="radio"/> Do Not Disturb
Show Pop-Up When Activating Normal State	No
Show Pop-Up When Activating MUR	No
Icon "Normal"	Room Normal
Icon "Make Up Room"	Make Up Room
Icon "Do Not Disturb"	Do Not Disturb

Figure 55. 1-Button Control - Room State.

- **State** [[Make Up Room](#) / [Do Not Disturb](#)]: sets the status to be switched together with Normal. The switched values are sent to the bus via the 1-byte object "[Ci] Room State - Control".
- **Show Pop-Up When Activating Normal State** [[No](#) / [Pop-Up 1](#) / ... / [Pop-Up 6](#)]: allows to select the pop-up to be displayed when the normal mode is activated.
- **Show Pop-Up When Activating MUR** [[No](#) / [Pop-Up 1](#) / ... / [Pop-Up 6](#)]: allows to select the pop-up to be displayed when the MUR mode is activated.

**Note:** *the pop-ups selected must be activated (see section 2.1.11.1).*

This control will have associated a dedicated object for the indicator (“[Ci] Room State - Status”), which is automatically updated after the control order is sent and when values are received from the bus.

#### 2.2.2.1.2.7 Enumeration

The box will behave analogously to the case of the switch, however the communication objects (control object “[Ci] Enumeration - Control” and the status “[Ci] Enumeration

- Status”) will be 1-byte. Up to six discrete states can be distinguished depending on the value that the status object acquires from the control or receives from the bus.

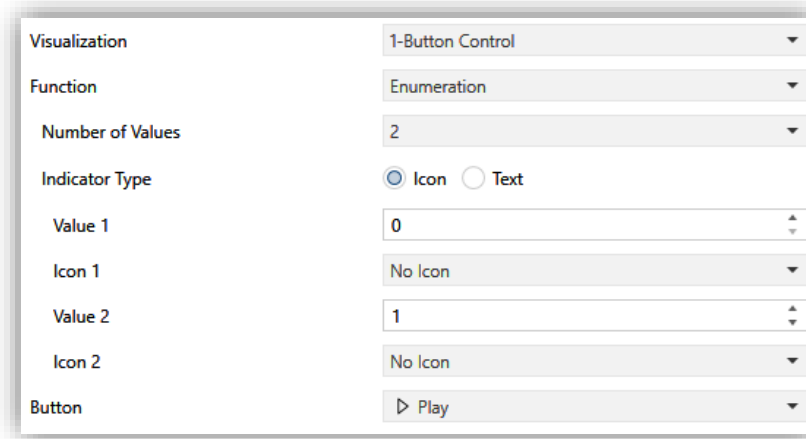

Visualization	1-Button Control
Function	Enumeration
Number of Values	2
Indicator Type	<input checked="" type="radio"/> Icon <input type="radio"/> Text
Value 1	0
Icon 1	No Icon
Value 2	1
Icon 2	No Icon
Button	▶ Play

Figure 56. 1-Button Control – Enumeration.

The available parameters are:

- **Number of Values** [1...2...6]: number of states that will be distinguished. For every distinguished state, the parameter **Value** [0...255] will become available together with the corresponding indicator.
- **Indicator Type** [Icon / Text]: allows selecting whether the status indicator which each value is represented will be text type or icon type. As many drop-down lists of icons or text boxes will be displayed as states have been enabled in the previous parameter.

### 2.2.2.1.3 2-BUTTON CONTROL

The box configured with this control type will have a button at the right and a state indicator. In addition, through **Function** parameter, it will be possible to select the specific function that the control will perform.

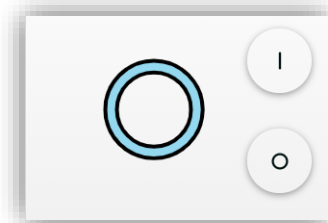

Figure 57. 2-Button Control

### 2.2.2.1.3.1 Switch

When the user touches the buttons in the box, a binary value will be sent through the “[Ci] Switch - Control” object, while the status object “[Ci] Switch - Indicator” will determine the icon or text shown in the box. The indicator will be updated automatically after each control order, and will also be able to receive values from the bus.

Visualization	2-Button Control
Function	Switch
Action	<input checked="" type="radio"/> Bottom = 0; Top = 1 <input type="radio"/> Top = 0; Bottom = 1
Indicator Type	<input checked="" type="radio"/> Icon <input type="radio"/> Text
Off Icon	Off
On Icon	On
Top Button	On
Bottom Button	o Off

Figure 58. 2-Buttons Control - Switch

- **Action** [Bottom = 0; Top = 1 / Top = 0; Bottom = 1]: sets the value to be sent when pressing each of the two buttons.
- **Indicator Type** [Icon / Text]: allows selecting whether the status represented by each indicator value will be text type or icon type.

### 2.2.2.1.3.2 Switch + Indicator

In the same way the previous control, when pressing in any of the controls configured as switch, the device will send the parameterised binary value to the bus through the object “[Ci] Switch - Control”. However, the indicator is independent and will only be updated according to the value received by the dedicated object.

Visualisation	2-Button Control
Function	Switch + Indicator
Action	<input checked="" type="radio"/> Bottom = 0; Top = 1 <input type="radio"/> Top = 0; Bottom = 1
Indicator Type	Counter
Size	<input checked="" type="radio"/> 1 Byte <input type="radio"/> 2 Bytes
Sign	<input checked="" type="radio"/> Signed <input type="radio"/> Unsigned
Units	
Top Button	On
Bottom Button	o Off

Figure 59. 2-Buttons Control - Switch + Indicator

- **Action** [Bottom = 0; Top = 1 / Top = 0; Bottom = 1]: sets the value to be sent when pressing each of the two buttons.
- **Indicator Type** [Counter / Scaling / Float / Temperature]: sets the indicator type. According to the selected indicator the objects. The range of values allowed in each case and the name of the corresponding object are listed in the table.

Function	Size	Sign	Range	Related Object
<u>Counter</u>	<u>1 Byte</u>	<u>Unsigned</u>	0 – 255	[Ci] Switch - 1-Byte Unsigned Int Status
		<u>Signed</u>	-128 – 127	[Ci] Switch - 1-Byte Signed Int Status
	<u>2 Bytes</u>	<u>Unsigned</u>	0 – 65535	[Ci] Switch - 2-Byte Unsigned Int Status
		<u>Signed</u>	-32768 – 32767	[Ci] Switch - 2-Byte Signed Int Status
<u>Scaling</u>	1 Byte		0 – 100	[Ci] Switch - Percentage Status
<u>Float</u>	<u>2 Bytes</u>		-671088.64 – 670433.28	[Ci] Switch - 2-Byte Float Status
<u>Temperature</u>	1 Byte		-99 – 199	[Ci] Switch - Temperature Status

Table 6. Numerical indicators – Switch + Indicator

- **Decimal Places** [0 / 1 / 2]: if the control is set as float, this parameter define the number of decimal places displayed in the box.
- **Units**: permits specifying the measuring units of the displayed value.

**Notes:**

- For percentage indicator, the symbol % always will be displayed as unit.
- The temperature indicator will be shown in °C or °F depending on the value of the active locale (see section 2.1.3). In addition, the following parameters will be available for this control type:
  - **Button to Change between °C and °F** [disabled / enabled]: enables a control that allows the temperature scale to be changed from the box itself:

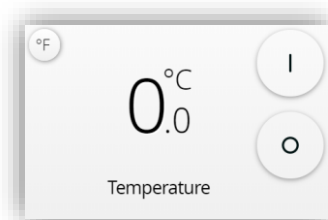

Figure 60. Temperature 2-Buttons Control

- **Include Plus Sign before Positive Numbers** [[disabled](#) / [enabled](#)]: shows the '+' sign before positive temperature values.

### 2.2.2.1.3.3 Two Objects (Short Press/Long Press)

Control for sending specific binary values both after a short or a long press on any of the two buttons. Two different objects are used to send values for short and long pulsations, "[Ci] Two objects - Short Press Control" and "[Ci] Two objects - Long Press Control".

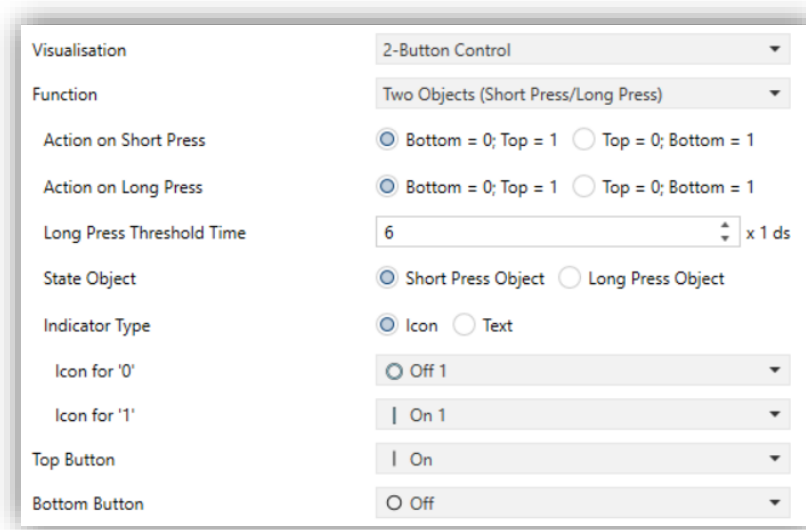

Figure 61. 2-Buttons Control - Two Objects

- **Action on Short / Long Press** [[Bottom = 0; Top = 1](#) / [Top = 0; Bottom = 1](#)]: sets the value to be sent when short / long pressing each of the two buttons.
- **Long Press Threshold Time** [[4...6...50](#)] [*ds*]: sets the minimum time the user should hold the button in order to consider it a long press.
- **State Object** [[Short Press Object](#) / [Long Press Object](#)]: allows setting the control command to which the status indicator, "[Ci] Two Objects – Switch Status", will obey. This object can also receive values from the bus.
- **Indicator Type** [[Icon](#) / [Text](#)]: allows selecting whether the status indicator which each value is represented will be text type or icon type.

### 2.2.2.1.3.4 Numerical Controls

If any of the functions "[Counter](#)", "[Scaling](#)" or "[Float](#)" is assigned to the control, user touches over the buttons will trigger the sending of a certain numerical value to the bus. This value will be progressively increased or decreased with every touch on top button

or button bottom, through the control object, while the box itself will permanently reflect the current value of the corresponding status object. This object can also receive values from the bus.

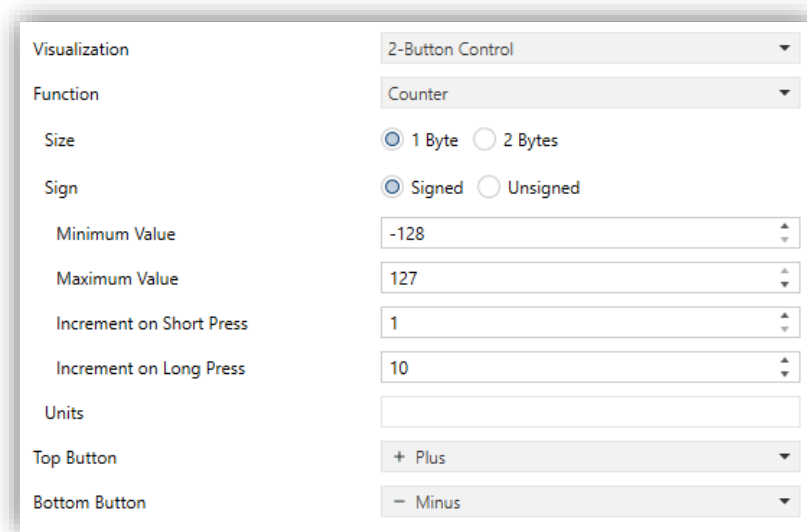

Figure 62. 2-Buttons Control - Numerical Control

The different types of 2-button numerical control available, their configuration options and the objects associated with them are listed in the following table:

Function	Size	Sign	Minimum Value	Maximum Value	Increment on short press	Increment on long press	Related Object
<i>Counter</i>	<i>1 Byte</i>	<i>Signed</i>	<i>[-128...127]</i>	<i>[-128...127]</i>	<i>[1...127]</i>	<i>[1...10...127]</i>	[Ci] Integer - 1-Byte Signed Status [Ci] Integer - 1-Byte Signed Control
		<i>Unsigned</i>	<i>[0...255]</i>	<i>[0...255]</i>	<i>[1...255]</i>	<i>[1...10...255]</i>	[Ci] Integer - 1-Byte Unsigned Status [Ci] Integer - 1-Byte Unsigned Control
	<i>2 Byte</i>	<i>Signed</i>	<i>[-32768...32767]</i>	<i>[-32768...32767]</i>	<i>[1...32767]</i>	<i>[1...32767]</i>	[Ci] Integer - 2-Byte Signed Status [Ci] Integer - 2-Byte Signed Control
		<i>Unsigned</i>	<i>[0...65535]</i>	<i>[0...65535]</i>	<i>[1...65535]</i>	<i>[1...65535]</i>	[Ci] Integer - 2-Byte Unsigned Status [Ci] Integer - 2-Byte Unsigned Control
<i>Scaling</i>	1 Byte		<i>[0...100]</i>	<i>[0...100]</i>	<i>[1...100]</i>	<i>[1...10...100]</i>	[Ci] Percentage - Status [Ci] Percentage - Control
<i>Float</i>	2 Byte		<i>[-671088.64...670433.28]</i>	<i>[-671088.64...670433.28]</i>	<i>[0.1...0.5...670433.28]</i>	<i>[0.1...1...670433.28]</i>	[Ci] Float - 2-Byte Status [Ci] Float - 2-Byte Control

Table 7. Numerical Control 2-Button

- **Decimal Places** *[0 / 1 / 2]*: if the control is set as float, this parameter define the number of decimal places displayed in the box.
- **Units**: permits specifying the measuring units of the displayed value. For percentage indicator, the symbol % always will be displayed as unit.

### 2.2.2.1.3.5 Enumeration

The box will behave analogously to the case of the switch, however the communication objects (control object “[Ci] Enumeration - Control” and the status “[Ci] Enumeration - Status”) will be 1-byte. Up to six discrete states can be distinguished depending on the value that the status object acquires from the control or receives from the bus.

Visualization	2-Button Control
Function	Enumeration
Number of Values	2
Indicator Type	<input checked="" type="radio"/> Icon <input type="radio"/> Text
Value 1	0
Icon 1	No Icon
Value 2	1
Icon 2	No Icon
Top Button	^ Up Arrow
Bottom Button	v Down Arrow

Figure 63. 2-Buttons Control - Enumeration

- **Number of Values** [1...2...6]: number of states that will be distinguished. For every distinguished state, the parameter **Value** [0...255] will become available together with the corresponding indicator.
- **Indicator Type** [*Icon* / *Text*]: allows selecting whether the status indicator which each value is represented will be text type or icon type. As many drop-down lists of icons or text boxes will be displayed as states have been enabled in the previous parameter.

### 2.2.2.1.3.6 Two Scene

Analogously to the 1-button scene control, 2-button scene controls allows sending the KNX bus a scene value, however in this case there will be two buttons in the box, each of which can be configured independently.

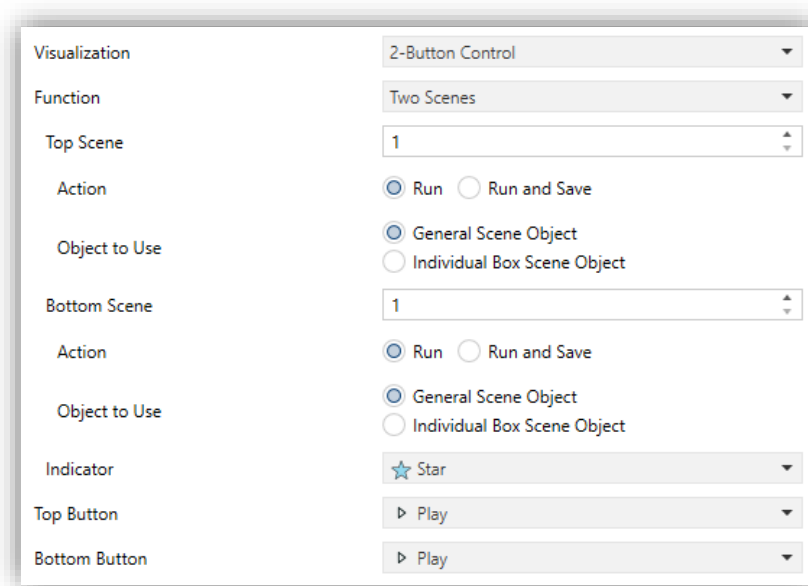

Figure 64. 2-Button Control – Two Scenes

- **Top / Bottom Scene [1..64]**: value of the scene that will be sent to the bus after pressing on the top and bottom button.
  - **Action [Run / Run and Save]**: sets whether the device will only send orders to execute specified scene (after a short press) or if will be possible to send orders to save the scene (after a long press).
  - **Object to Use [General Scene Object / Individual Box Scene Object]**: specifies whether the scene value will be sent through the object "[General Scenes: Send]" or through the individual object for each: "[Ci] Two Scenes - Top Scene: Send" and/or "[Ci] Two Scenes - Bottom Scene: Send".

#### 2.2.2.1.3.7 Shutter

Shutter control permits sending move up and move down ("[Ci] Shutter – Move Control") or stop ("[Ci] Shutter – Stop/Step Control") to control a shutter actuator connected to the bus by pressing the buttons in the box. In addition, the box will contain an indicator that will permanently show, as a percentage, the value of the status object ("[Ci] Shutter - Percentage Status").

In case of configuring **Slider** type control, the control value will be sent through the "[Ci] Shutter – Percentage Control" object and the following parameter is also displayed:

- **Slats Control [disabled / enabled]**: enables a new slider to control the position of the slats via the "[Ci] Shutter – Slats Control" object. The position of the slats will be received via the "[Ci] Shutter – Slats Status" object.

If the **Motion Status Object Available** parameter is enabled, a new “[Ci] Shutter – Move Status” object will appear to indicate to the device whether the shutter is currently moving. If the shutter is in motion, the indicator icon will change and become clickable, thus allowing the shutter movement to stop. If this parameter is not enabled, the indicator icon will always be clickable, sending the command to stop the shutter when pressed.

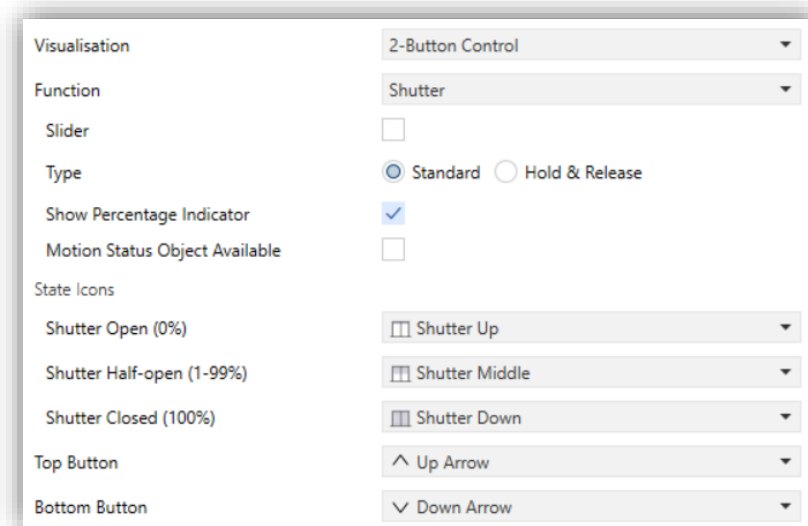

Figure 65. 2-Buttons Control - Shutter

- **Type:** set the desired behaviour for the buttons:
  - [[Standard](#)]: a long press will make the device send to the KNX bus an order to start moving the shutter (upwards or downwards, with the top or bottom button respectively), while a short press will make it send a stop order (or step up / step down).
  - [[Hold & Release](#)]: as soon as the button is held, the device will send the KNX bus an order to start moving the shutter (upwards or downwards, with the top or bottom button respectively). Once the button is released, it will send an order to stop the shutter.
- **Show Percentage indicator** [[disabled](#) / [enabled](#)]: enables or disables the shutter position indicator (in percentage) in the box.
- **Motion Status Object Available** [[disabled](#) / [enabled](#)]: enables the object through which the control will be informed if the shutter is in motion.

### 2.2.2.1.3.8 Dimmer

The light control function permits making use of the two buttons in the box to send orders to a light dimmer, either through a binary object or through a 4-bit object. Moreover, the box will permanently display the current value of the dimming status object (“**[Ci] Light – Percentage Status**”), which needs to be linked to the analogous object from the dimmer (as it does not get automatically updated on button presses).

There will also be a central clickable icon to send an on/off command by clicking on the icon “**[Ci] Light – Switch control**”.

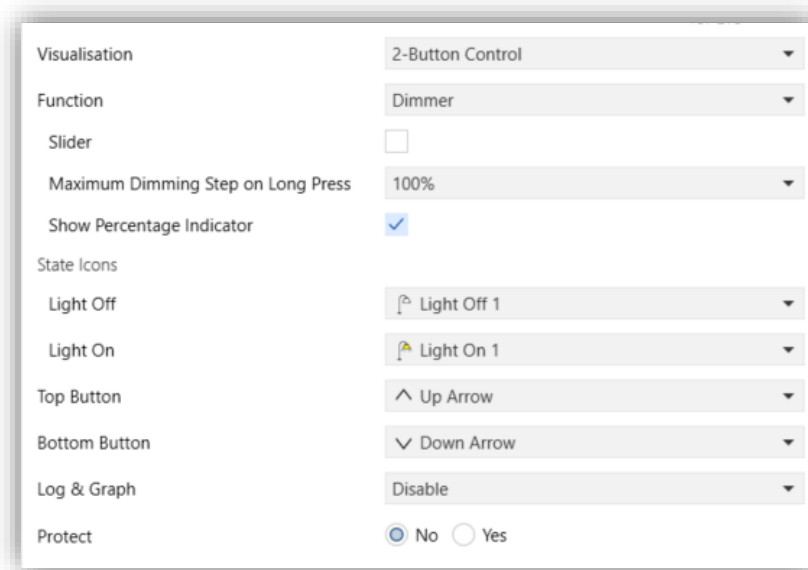

Figure 66. 2-Buttons Control - Dimmer

The parameters available are:

- **Slider** [*disabled / enabled*]: enables the option to control the checkbox with slider instead of buttons.
- **Maximum Dimming Step on Long Press** [*100% / 50% / 25% / 12.5% / 6.25% / 3.1% / 1.5%*]: sets the increase or decrease in the light level that will be requested, via object “**[Ci] Light – 4-bits Dimming Control**”, from the dimmer with each long press on the top or bottom button respectively.

After a short press on the top button the value “1” will be sent through the “**[Ci] Light - Switch Control**” binary object, while a short press on the bottom button will trigger the sending of the value “0”.

- **Show Percentage Indicator** [*disabled / enabled*]: enables or disables the shutter status indicator in the box.

**Note:** *most light dimmers implement light step dimming progressively (i.e., sending a dimmer a step order of 25% typically does not imply that the light level is suddenly incremented/decremented by 25%, but a progressive increment or decrement of the light level by 25% which is in fact interrupted if a stop order arrives (such order is sent by the touchscreen when the user releases the button). Due to this behaviour, it is advised to parameterise dimming steps of 100%, so that the user can perform a complete dimming (from totally off to totally on, or vice versa) or a partial dimming by simply holding the button and then releasing it as soon as he gets the desired light level, therefore with no need of performing successive long presses for regulations greater than the parameterised step.*

Additionally, the dimmer control will have the 1-byte object "**[Ci] Light - 1-Byte Percentage (Only Schedulers, Macros and Voice Control)**" which will be used by schedulers and macros for a precise lighting control.

In case of configuring it as a **Slider**, the control will be done through the object "**[Ci] Light – 1-Byte Percentage Control**". The following parameters will be displayed:

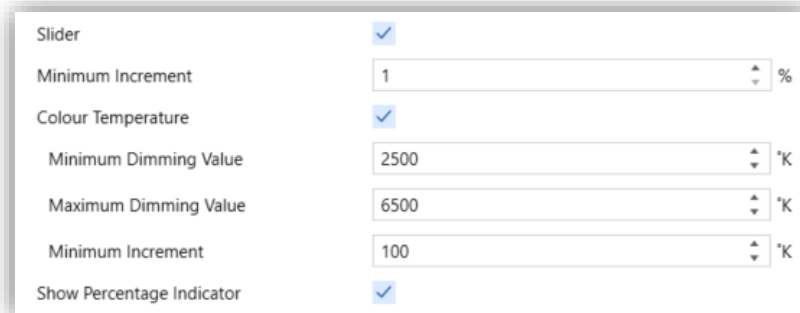

Slider	<input checked="" type="checkbox"/>
Minimum Increment	1 %
Colour Temperature	<input checked="" type="checkbox"/>
Minimum Dimming Value	2500 K
Maximum Dimming Value	6500 K
Minimum Increment	100 K
Show Percentage Indicator	<input checked="" type="checkbox"/>

Figure 67. Dimming control with slider

- **Minimum Increment** [*1...100*] [%]: step value that the slider will have.
- **Colour Temperature** [*disabled / enabled*]: enables an additional slider to control the colour temperature through the objects "**[Ci] Light – Colour Temperature Control**" and "**[Ci] Light – Colour Temperature Status**".
  - **Minimum Dimming Value** [*1000...2500...20000*] [K]: sets the minimum value that can be reached by the slider.

- **Maximum Dimming Value** [1000...6500...20000] [K]: sets the maximum value that can be reached by the slider.
- **Minimum Increment** [1...100...1000] [K]: step value that the slider will have.

#### 2.2.2.1.4 CLIMATE CONTROL

---

This category covers a set of functions related to the climate control. The available options for **Function** (and for the dependent parameters) are as follows:

##### 2.2.2.1.4.1 *Temperature Setpoint*

---

This function permits controlling the temperature setpoint of an external thermostat by means of a two-button box and of the parameters enabled to that effect: “[Ci] Setpoint - Temperature Control” for the control and “[Ci] Setpoint - Temperature Status” for the status. It is also possible to enable a real temperature indicator that will be updated through the object “[Ci] Setpoint - Ambient Temperature Indicator”.

The box itself will permanently reflect the value in °C o °F of the status object, whose value gets automatically updated after sending control orders (that is, after pressing the buttons), being even possible to receive values from the bus, for example, from the corresponding setpoint status object from the external thermostat.

Therefore, after every press on the temperature increment button, the bus will be sent (through the control object) a certain value, progressively increased on every button press until the parameterisable maximum setpoint value has been reached. Analogously, after every press on the temperature decrement button, the bus will be sent a progressively decreased value until the parameterisable minimum setpoint value has been reached.

Figure 68. Climate Control – Temperature Setpoint

The parameters available are:

- **Slider** [*disabled / enabled*]: enables the option to control the checkbox with slider instead of buttons.
- **Button to Change between °C and °F** [*disabled / enabled*]: enables a control that allows the temperature scale to be changed from the box itself.
- **Include Plus Sign before Positive Numbers** [*disabled / enabled*]: adds the '+' sign before positive temperature values.
- **Indicator Type:**
  - [*Just Setpoint Temperature*]: only the setpoint temperature will be displayed.
  - [*Setpoint is Main and Real is Secondary*]: this option shows two temperatures at the same time. The real temperature will be displayed below the setpoint temperature in a smaller font size and accompanied by a house icon.
  - [*Setpoint is Secondary and Real is Main*]: this option shows two temperatures at the same time. The setpoint temperature will be displayed below the real temperature in a smaller font size and accompanied by a thermometer icon.



Figure 69. Setpoint Temperature with different indicator types

- **Different Limits for Cool/Heat Mode** [*disabled* / *enabled*]: sets a different upper and lower limit for cool mode and heat mode.
- **Minimum Value** [-99...10...199]: minimum value than can be reached by the control after a number of presses on the bottom button. If the parameter **Different Limits for Cool/Heat Mode** is enabled, this parameter will be duplicated, one for cooling mode and one for heating mode.
- **Maximum Value** [-99...30...199]: maximum value than can be reached by the control after a number of presses on the top button. If the parameter **Different Limits for Cool/Heat Mode** is enabled, this parameter will be duplicated, one for cooling mode and one for heating mode.
- **Increment on Short Press** [0.1...0.5...10]: sets the increase or decrease step to be applied to the current value on every short press over the top or bottom buttons, respectively.
- **Increment on Long Press** [0.1...1...10]: sets the increase or decrease step to be applied to the current value on every long press over the top or bottom buttons, respectively.

**Note:** Long and short increments are applied in °C regardless of the scale used.

#### 2.2.2.1.4.2 Mode

This function turns the box into a climate mode control.

When this type of mode control is assigned to the box, two communication objects are enabled: the “[Ci] **Mode - Control**” control object, and the “[Ci] **Mode - Status**” status object. Depending on the mode selected by the user, the control object will be sent to the bus a certain value, after which the box will display the icon that corresponds to the new mode.

Two mode control types are possible: Heat / Cool control type and the Extended (HVAC) control type.

### ● Mode Type:

- [[Heat/Cool](#)]: Selecting this type of mode control turns the box into a 2-button control one of which will activate the Heat mode, while the other one will activate the Cool mode. A centered indicator will reflect, as an icon, the currently active mode.

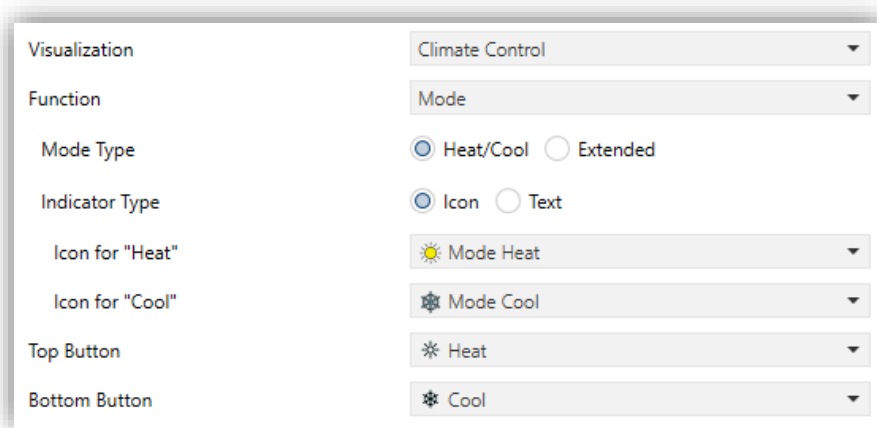

Figure 70. Climate Control - Heat/Cool Mode

When the user activates the Cool mode, the device will send the value "0" through the control object, while on the activation of the Heat mode the value "1" will be sent. Moreover, the box will automatically commute between one icon and the other every time the user executes a mode change, and also on the reception of a new value (from the bus) through the status object.

- [[Extended](#)]: Selecting this type of mode control turns the box into a 2-button control, which permit sequentially commuting among the different HVAC climate modes. A centred indicator will reflect, as an icon, the currently active mode.

Up to five modes [[Auto / Heat / Cool / Fan / Dry](#)] are available, each of which can be enabled/disabled in ETS by means of the proper checkbox, which permits setting which of all the five extended modes will be included into the sequential scrolling implemented by the buttons.

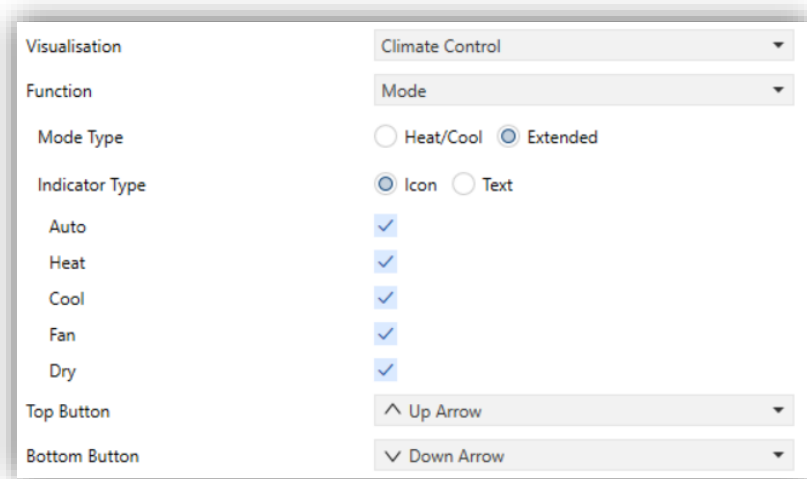

Figure 71. Climate Control - Extended Mode.

Depending on the mode selected by the user, the control object will be sent to the bus a certain value (see Table 8). The box will display the icon that corresponds to the new mode. Additionally, if the status object receives from the bus a value that represents any of the modes, the box will adopt the corresponding icon, while if an unrecognised value is received, no icon will be shown.

Mode	Value sent
Auto	0 (0x00)
Heat	1 (0x01)
Cool	3 (0x03)
Fan	9 (0x09)
Dry	14 (0x0E)

Table 8. HVAC Mode vs. Object Value

- **Indicator Type** [*Icon / Text*]: enables to select whether the status indicator which each value is represented will be text type or icon type. As many drop-down lists of icons or text boxes will be displayed as modes have been enabled.

### 2.2.2.1.4.3 Fan Control

This function implements a 2-button (increase / decrease) fan control, as well as an icon indicator.

When this function is assigned to the box, a control object and a 1-byte status object (“**[Ci] Fan – Percentage Status**”) are enabled. The status object (which needs to be

linked to the status object of the fan actuator) will express, as a percentage, the value of the current fan level, which will be represented with a variable icon on the box.

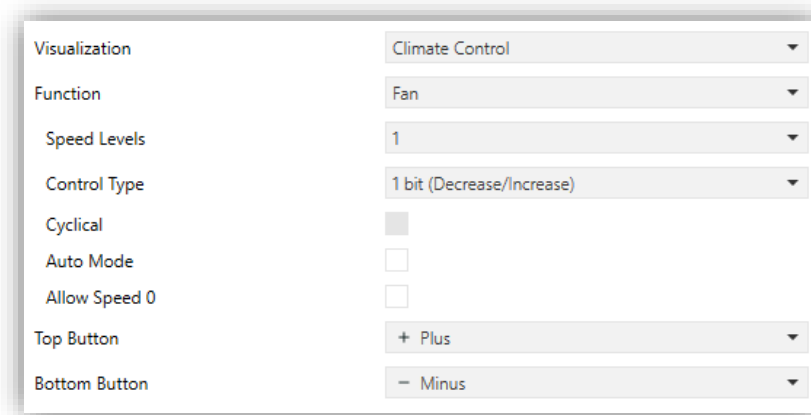

Figure 72. Climate Control - Fan

- **Speed Levels** [1...5]: sets how many speed levels will be available in the control. 1 to 5 levels.
- **Control Type**: sets the type of the communication objects that will control the fan level.
  - [1 bit (decrease/increase)]: orders of speed increase/decrease are sent through the one-bit object “[Ci] Fan – Binary Control”.
  - [Scaling]: scaling values are sent through the one-byte object “[Ci] Fan – Percentage Control”.
  - [Enumeration]: integer values are sent through the one-byte object “[Ci] Fan – Enumeration Control”.
- **Cyclical** [disabled / enabled]: sets whether scrolling through the speed levels is circular or not. If checked, an increase order in the maximum level switches to the minimum and vice versa (in the minimum level a decrease order switches to the maximum). In case of having **Control Type: 1 bit (Decrease/Increase)**, this parameter cannot be enabled.
- **Auto Mode** [disabled / enabled]: sets whether the fan Auto mode will be available or not. If checked, the following parameters are also shown.
  - **Dedicated Object for Auto Mode** [disabled / enabled]: sets how the Auto mode should be activated. In the absence of a dedicated object, the Auto fan mode will be activated by switching to fan level 0.

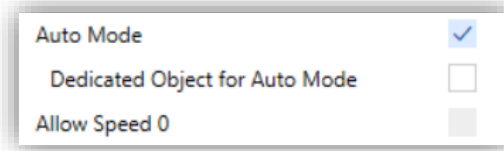

Figure 73. Fan Control – Auto Mode.

In case to be disabled (supposing that **Speed Levels** has been set to “3”), the fan levels that can be navigated through short presses are:

Auto ( 0 )	Minimum	Medium	Maximum
------------	---------	--------	---------

On the other hand, marking the checkbox enables the one-bit object “**Fan - Auto mode**”, which will trigger the Auto mode when it receives the value “1” or “0”, depending on the subsequent parameter **Value to Set the Auto Mode** [[Send 0 / Send 1](#)].

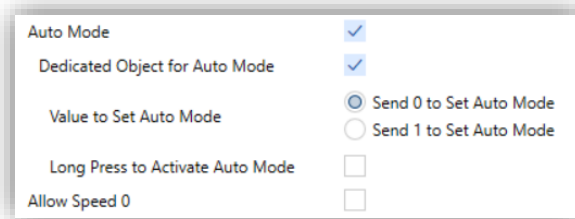

Figure 74. Fan Control – Dedicated Object for Auto Mode

However, in this case the Auto mode can be activated in two ways (and mutually exclusive):

- By short press: Auto mode can be reached as a further level above the maximum one. In this case the fan levels activated by short presses are (note that **speed 0 is optional**):

( 0 )	Minimum	Medium	Maximum	Auto
-------	---------	--------	---------	------

- By long press on any of the buttons of the control (requires checking **Long Press to Activate Auto Mode** [[disabled / enabled](#)]). A further long press deactivates back the Auto mode

In this case the fan levels reachable through short presses are (**speed 0 is optional**):

( 0 )	Minimum	Medium	Maximum
-------	---------	--------	---------

Here, the Auto mode is only activated by long press.

- **Allow speed 0** [*disabled/enabled*]: sets whether the speed level 0 will be present or not. When the **Auto Mode without a dedicated object** has been configured, this option will be necessarily activated.

#### 2.2.2.1.4.4 Special Mode

Boxes configured as special mode controls include two buttons that let the user sequentially commute between the different special climate modes, as well as an icon indicator that will adopt an aspect or another depending on the currently active special mode.

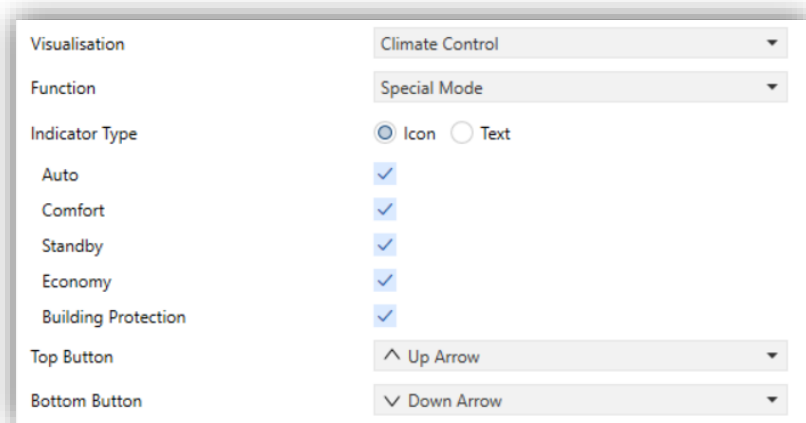

Figure 75. Climate Control - Special Mode

When this function is assigned to the box, two 1-byte objects (“**[Ci] Special Mode - Control**” as the control object, and “**[Ci] Special Mode - Status**” as the status object) will be enabled. The former will be sending the bus the value that corresponds to the mode that the user selects by touching the buttons (see Table 9), while the status object (which can receive values from the bus although it gets self-updated as well on button presses) will determine the indicative icon represented in the box at any time. If this object receives an unrecognised value from the bus, no icon will be displayed in the indicator.

Special Mode	Icon	Object Value
Comfort		1 (0x001)
Standby		2 (0x002)
Economy		3 (0x003)
Protection		4 (0x004)

Auto Mode		5 (0x005)
-----------	---	-----------

Table 9. Special Modes vs. Icon vs. Object Value

- **Indicator Type** [*Icon* / *Text*]: allows selecting whether the status indicator which each value is represented will be text type or icon type. If “Text” is selected, as many text boxes will be displayed as modes have been enabled.

## 2.2.2.1.5 OTHER

### 2.2.2.1.5.1 RGB Control

This function is intended for sending orders to three-colour LED light regulators.

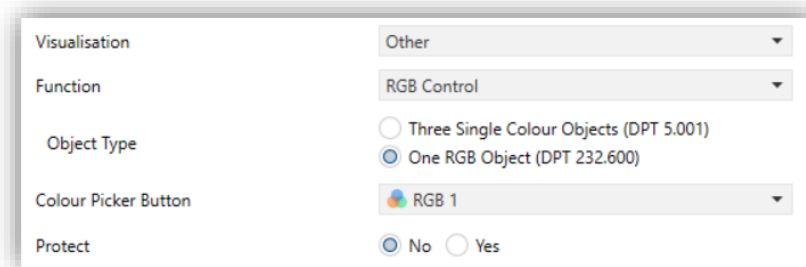

Figure 76. RGB Control

When the function is assigned to the box, the following parameter come up:

- **Object Type** [*Three Single Colour Objects (DPT 5.001)* / *One RGB Object (DPT 232.600)*]: permits selecting what type of object will be used for controlling the light level of the RGB channels.
  - “Three Single Colour Objects (DPT 5.001)”: three 1-byte objects (“**[Ci] RGB - Red Channel**”, “**[Ci] RGB - Green Channel**” and “**[Ci] RGB - Blue Channel**”) will be enabled, which can send orders and receive statuses.
  - “One RGB Object (DPT 232.600)”: only one 3-byte object will be enabled (“**[Ci] RGB - RGB Colour**”). The light levels of the three channels are sent (and received) concatenated into the above 3-byte object.

Regarding the RGB control boxes themselves, a central label will permanently show the colour and current light level (which is determined by the channel with the highest current light level). This **indicator** gets updated automatically as the user interacts with the box, but is also conditioned by the values received from the bus through the already described objects. Regarding the RGB control boxes themselves, a central clickable icon show the

colour and current light level (which is determined by the channel with the highest current light level). This **icon** gets updated automatically as the user interacts with the box, but is also conditioned by the values received from the bus through the already described objects.

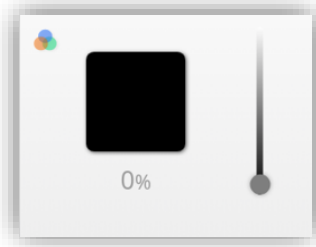

Figure 77. RGB (Box)

In addition, the boxes have the following features:

- **Short-pressing** on the clickable icon send on/off control commands via the "[Ci] RGB - On/Off" object.
- The slider on the right-hand side of the box adjust the intensity of the set colour by increasing or decreasing the value of each colour component.
- The upper left button, when pressed, launches a pop-up containing a **colour wheel** that permits the selection of a light level for every channel. Within this, there is an area to choose the colour and a slider to adjust the intensity of the colour.

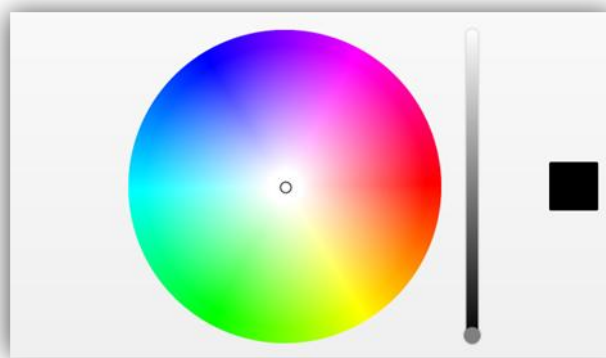

Figure 78. RGB/RGBW Colour Selector

#### 2.2.2.1.5.2 RGBW Control

The RGBW control is **analogous to the above** RGB control, although it also lets controlling a specific **fourth channel** for white ("[Ci] RGBW - White Channel").

It also has the particularity of being able to choose a colour object.

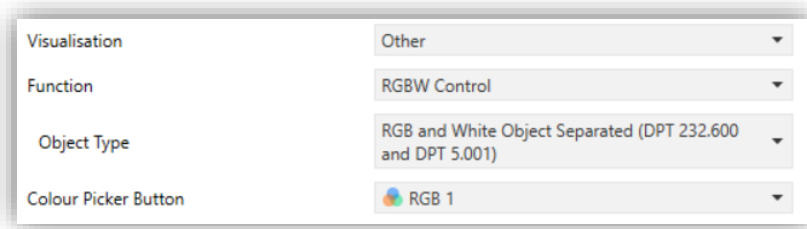

Figure 79. RGBW Control

- **Object Type** [[Four Single Colour Objects \(DPT 5.001\)](#) / [RGB and White Objects Separated \(DPT 232.600 and DPT 5.001\)](#) / [One RGBW Object \(DPT 251.600\)](#)]: permits selecting what type of object will be used for controlling the light level of the RGBW channels.

- **“Four Single Colour Objects (DPT 5.001)”**: 1-byte object is enabled for each channel (“**[Ci] RGBW – Red Channel**”, “**[Ci] RGBW – Green Channel**”, “**[Ci] RGBW – Blue Channel**” and “**[Ci] RGBW – White Channel**”).
- **“RGB and White Objects Separated (DPT 232.600 and DPT 5.001)”**: two objects will be enabled, one 3-byte object analogous to RGB (“**RGBW - RGB Color**”) and a 1-byte object for the white channel (“**[Ci] RGBW - White Channel**”).
- **“One RGBW Object (DPT 251.600)”**: a 6-bytes object will be enabled: “**[Ci] RGBW - RGBW Colour**” through which the light levels of the four channels are sent and received concatenated.

### 2.2.2.1.5.3 Page Direct Link

This control allows a shortcut to the page indicated by parameter. To configure a box as a page direct link type control, the following parameter must be set in addition to the icon:

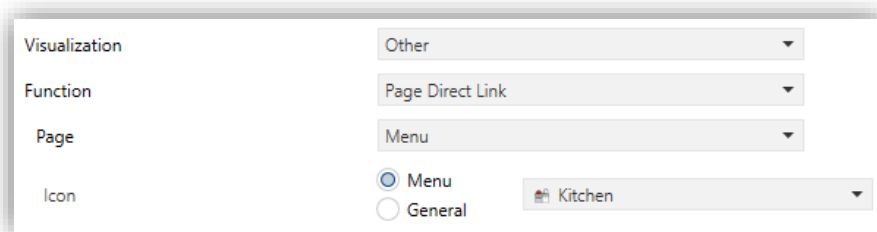

Figure 80. Page Direct Link

- **Page** [[Menu / Configuration / Page 1 / ... / Page 12](#)]: page that will be accessed.

#### 2.2.2.1.5.4 Alarm

Boxes configured as alarms perform user warnings on anomalous events. For this purpose, boxes of this type are related to the binary object “[Ci] Alarm - Trigger” that permits receiving alarm messages from the bus.

The **blinking warning icon** shows that the alarm is active and not confirmed. This icon will also appear in the upper right corner of the button of the page where the alarm is located.

When an alarm has been activated, there are two different options:

- Pressing the ‘Home’ button: it will silence the notification, but it will not confirm the alarm. The alarm box icon will continue blinking.
- Press the ‘OK’ button in the alarm box: this will confirm the alarm, and cause the icon to stop blinking. When this button is pressed, the binary object “[Ci] Alarm - Confirmation” with the value “1” will be sent through the bus. If this object receives from the bus the value “1”, the alarm will also be confirmed, having the same effects.

The alarm will definitely become inactive once it has been confirmed and, in addition, once the “[Ci] Alarm - Trigger” object goes back to the “no alarm” state (the order of these two events is irrelevant), after which the box icon and the page icon will finally turn off.

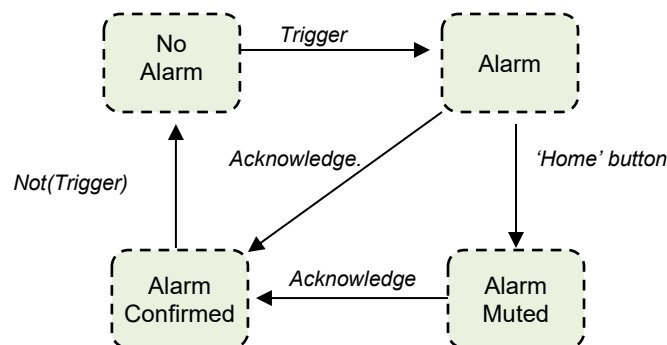
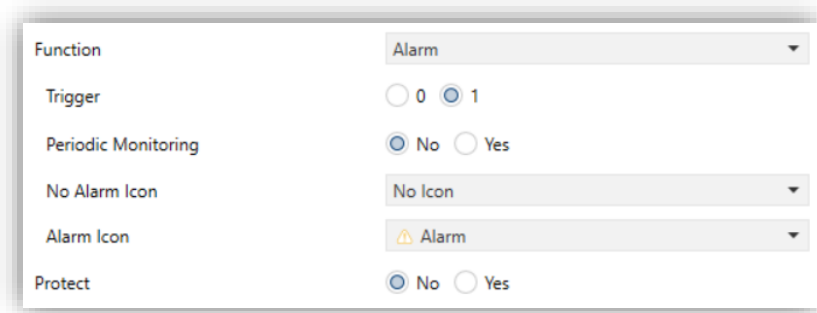

Figure 81. Alarm state diagram (case of confirmation previous to the alarm end)

There is also the possibility of **periodically monitoring** the status of the trigger object, for situations where this object is periodically received from the bus. This will let the device automatically assume the alarm situation if the “no alarm” value does not get sent through the trigger object after a certain time, for example upon failures of the transmitter. The maximum time window can be defined by parameter.

Alarm boxes permit configuring the following parameters:



Function	Alarm
Trigger	<input type="radio"/> 0 <input checked="" type="radio"/> 1
Periodic Monitoring	<input checked="" type="radio"/> No <input type="radio"/> Yes
No Alarm Icon	No Icon
Alarm Icon	Alarm
Protect	<input checked="" type="radio"/> No <input type="radio"/> Yes

Figure 82. Alarm

- **Trigger** [0 / 1]: defines the value that will trigger the alarm (“0” or “1”; it is “1” by default), i.e., the value that, when received through “[Ci] Alarm - Trigger”, should be interpreted as an alarm situation. Implicitly, this parameter also defines the inverse “no alarm” value.
- **Periodic Monitoring** [No / Yes]: activates or deactivates periodic monitoring of the alarm trigger object. When activated, the following parameter appears:
  - **Cycle Time** [30...65535] [s] [1...255] [min / h]: sets the maximum accepted time space without receiving the “no alarm” value before the touchscreen adopts the alarm situation.

#### 2.2.2.1.5.5 Chronothermostat

This control let the final user schedule the timed sending of **temperature setpoints orders** (preceded by switch-on orders) or **switch-off orders** to a thermostat through the objects “[Ci] Chronothermostat - On/Off Control” and “[Ci] Chronothermostat – Setpoint Control”.

To that end, setting the following parameters is necessary:

Visualisation	Other
Function	Chronothermostat
Minimum Setpoint Value	18 °C
Maximum Setpoint Value	30 °C
Enablement	<input checked="" type="radio"/> 0 = Disable; 1 = Enable <input type="radio"/> 0 = Enable; 1 = Disable
Off Icon	Chronothermostat (Clock) Off
On Icon	Chronothermostat (Clock) On
Config Button	Gear
Protect	<input checked="" type="radio"/> No <input type="radio"/> Yes

Figure 83. Chronothermostat

- **Minimum Setpoint Value** [-99 ... 18 ... 199] [°C]: minimum setpoint value that the user can be set on the chronothermostat panel (see Figure 85).
- **Maximum Setpoint Value** [-99 ... 30 ... 199] [°C]: maximum setpoint value that the user can be set on the chronothermostat panel (see Figure 85).
- **Enablement** [0 = Disable; 1 = Enable / 0 = Enable; 1 = Disable]: selects the polarity of the control object "[Ci] Chronothermostat - Enable", which will enable or disable the chronothermostat analogously as from the on-screen switch button of the box (see Figure 84). The box configured as a chronothermostat control looks as follows:



Figure 84. Chronothermostat box

The central clickable button will enable the **chronothermostat to be switched on or off**, i.e. to resume or stop the programmed sending. The **programming of the timed**

**actions** will be performed through the following pop-up window, visible by clicking on the upper button:

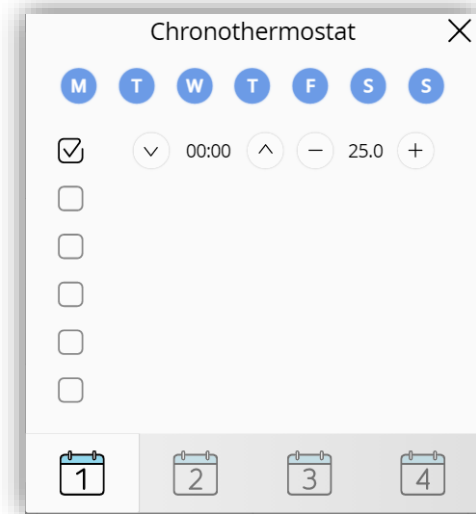

Figure 85. Chronothermostat panel

Each box configured as a chrono-thermostat contains **four pages** with **six customisable timers** each, being possible for the user to configure up to 24 timed actions.

For each of the six timed actions of each page it is necessary to select the **days of the week** on which the action should be performed, as well as the specific **time of day** (the first day of the week will depend on the parameterisation of device Locale; see section 2.1.3). After that, the user should select the **temperature setpoint** that will be sent.

Instead of a temperature setpoint, it is also possible to send a **switch-off** order to the thermostat. In such case, the user must successively press on the above control until one of the range limits is reached, after which the word “**OFF**” will show on the screen instead of a temperature value.

#### 2.2.2.1.5.6 Scheduler

This control allows access to the general scheduler panel. To do so, it is necessary to enable this functionality in the configuration tab (see section 2.1.2).

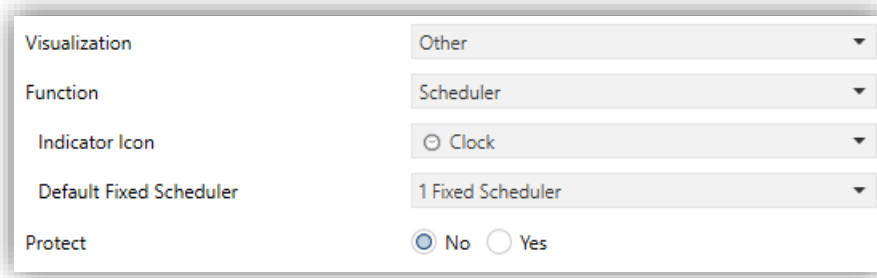

Figure 86. Scheduler

When the function is assigned to the box, the following parameter come up:

- **Default Fixed Scheduler** [*1 Fixed Scheduler / ... / 30 Fixed Scheduler*]: defines which scheduler should be opened by default when accessing the general scheduler panel from this box.

#### 2.2.2.1.5.7 Macro

This control configures the sending of up to **30 orders** sequentially, establishing a delay between one order and another, defined in seconds.

The box configured as **Macro** looks as follows:

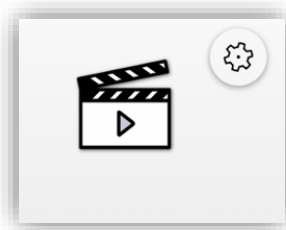

Figure 87. Macro box

The **central clickable button** start/stop the macro and **upper button** open the macro configuration panel. Within this panel, the actions to be executed with the delay configured for each action are displayed in order.

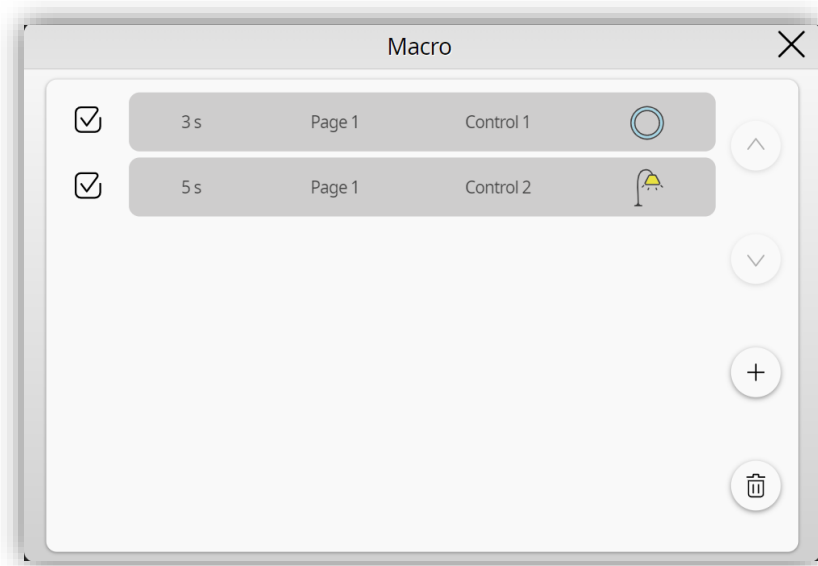

Figure 88. Macro configuration panel

Macro configuration is very similar to schedulers configuration (see section 2.1.6) with some minor differences:

- The time field is replaced by a **delay** to trigger the action. This delay starts counting from when the previous action was triggered or from when the macro started in case it is the first action.
- It is possible to **reorder** the actions by long pressing on the action to be moved (while out of edit mode). After the long press, the action will be marked in blue and it is possible scroll the action through the list. Once the action has been placed, it will be necessary to press the validate button or close the panel to save the changes.

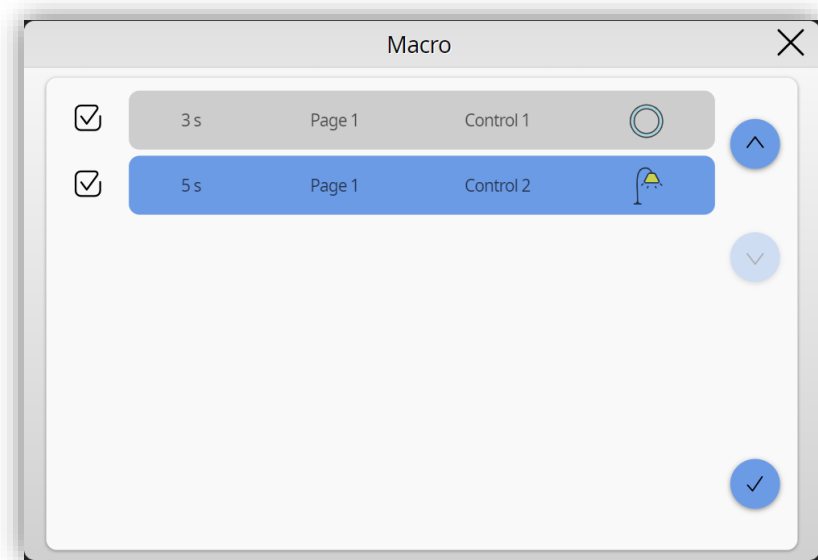

Figure 89. Reordering of actions (Macros)

**Note:** within a macro it is only possible to configure actions with a **security level equal to or lower than the security level of the box.**

When configuring this control in ETS, the following parameters are displayed:

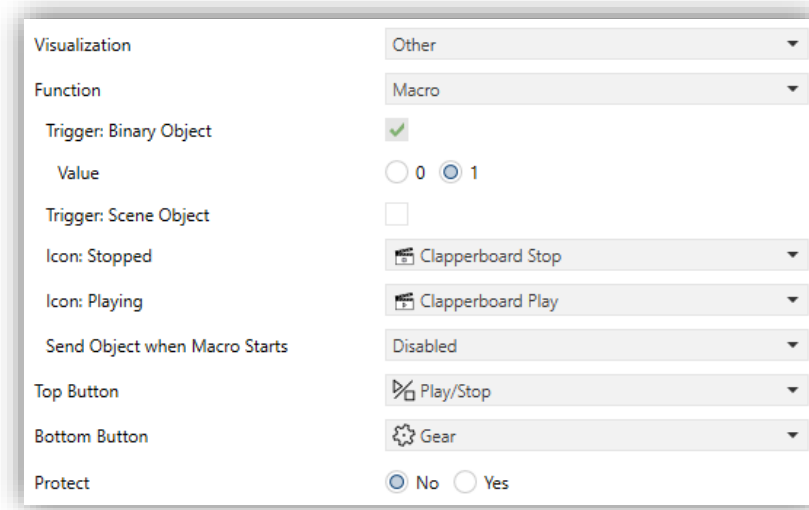

Figure 90. Macro

- **Trigger: Binary Object** [\[enabled\]](#): runs/stops the macro through the object “[Ci] Macro - Trigger”.
  - **Value** [\[0/1\]](#): polarity of the binary trigger object.
- **Trigger: Scene Object** [\[disabled / enabled\]](#): runs/stops the macro through the object “[General] Scenes: Receive”. When enabled, the following parameters are displayed:
  - **Scene to start (0 = Disabled)** [\[0 ... 64\]](#): scene to run the macro.
  - **Scene to stop (0 = Disabled)** [\[0 ... 64\]](#): scene to stop the macro.
- **Send Object when Macro Starts** [\[Disabled / Binary Value / Scene\]](#): sets how to notify that the macro has started.
  - **Binary Value**: it is notified by the object “[Ci] Macro – Notification Control”. It shall be possible to choose the polarity of the object via the parameter **Value** [\[0/1\]](#).
  - When **Scene** option is chosen, the following parameters will appear:
    - **Scene Number** [\[1 ... 64\]](#): scene sent when macro starts.

- **Scene Object** [[General Scene Object](#) / [Individual Box Scene Object](#)]: sets the object through which the scene is sent. In case of choosing the [Individual Box Scene Object](#) option the object "[Ci] Macro – Notification Control" will be displayed.

**Note:** security in this control can be applied to the whole box or only to the configuration button, thus allowing to execute a macro, even if the user does not have permissions to configure it.

#### 2.2.2.1.5.8 Timer

---

This control makes it possible to schedule the sending of binary or scene orders at a specific time (either on certain days of the week or only once).

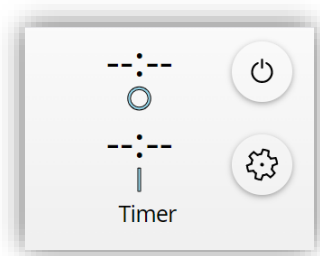

Figure 91. Timer box

The box consists of 2 buttons. The upper button enables/disables the timer (all actions will be displayed as --:-- if the timer is disabled), while the lower button opens the configuration panel.

When the timer is enabled, the configured hours will be displayed in the box. In addition, the icon ① will appear on the left side of the box if it has been configured as a **one-shot timer** or the days of the week if it has been configured as a **daily/weekly timer**.

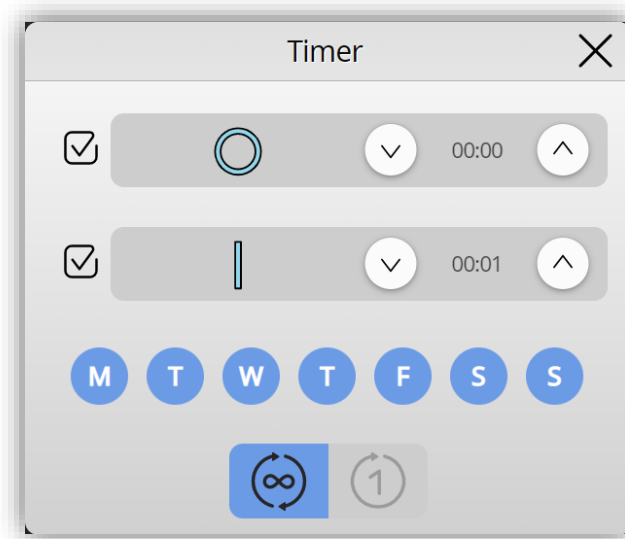

Figure 92. Timer configuration panel

Configuration panel has the following elements:

- **Actions to send:** if binary timer is parameterised, up to 2 actions can be enabled, one of them to send on and the other to send off, not allowing both actions to be disabled at the same time. If scene type timer is parameterised, the action will always be shown with the parameterised text/icon. Within each action, the time to send every action is configured.
- **Days of the week:** set the days of the week on which sending will occur.
- **Type of timer:**
  - **Daily/Week timer** (∞): the configured actions will be sent on the selected *days of the week* without ever being disabled.
  - **One-shot timer** (1): the actions will be sent when the configured time is reached. Once all actions have been sent, the timer is disabled.

**Note:** *days of the week will only be displayed when the timer is a daily/weekly timer.*

Closing the configuration panel causes the configured actions to be saved and the checkbox to be enabled if it is disabled.

When configuring this control in ETS, the following parameters are displayed:

Visualization	Other
Function	Timer
Timer Type	<input checked="" type="radio"/> Binary Value <input type="radio"/> Scene
Indicator Type	<input checked="" type="radio"/> Icon <input type="radio"/> Text
Off Icon	Off
On Icon	On
Enablement	<input checked="" type="radio"/> 0 = Disable; 1 = Enable <input type="radio"/> 0 = Enable; 1 = Disable
On/Off Button	On/Off
Bottom Button	Gear
Protect	<input checked="" type="radio"/> No <input type="radio"/> Yes

Figure 93. Timer

- **Timer Type** [[Binary Value](#) / [Scene](#)]: sets the type of object to be sent when the configured time is reached. If the [Binary value](#) option is chosen, it will be sent through the object "[Ci] Timer - Switch Control". If the Scene option is chosen, the following parameters will appear:
  - **Scene Number** [[1 ... 64](#)]: scene sent when configured time is reached.
  - **Scene Object** [[General Scene Object](#) / [Individual Box Scene Object](#)]: sets the object through which the scene is sent. In case of choosing the [Individual Box Scene Object](#) option the object "[Ci] Timer – Send Scene Control" will be displayed.
- **Indicator Type** [[Icon](#) / [Text](#)]: sets whether the indicator displayed within the action is an icon or text.
- **Enablement** [[0 = Disable; 1 = Enable](#) / [0 = Enable; 1 = Disable](#)]: selects the polarity of the control object "[Ci] Timer - Enable", which will enable or disable the timer analogously as from the on-screen switch button of the box.

**Note:** security in this control can be applied to the whole box or only to the configuration button, thus allowing to enable the timer, even if the user does not have permissions to configure it.

### 2.2.2.1.5.9 Energy Monitor

This control allows access to power and energy consumption graphs.

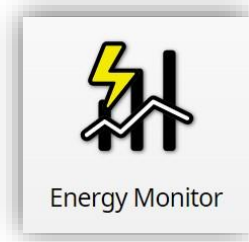

Figure 94. Energy monitor box

It is necessary to enable this functionality in the configuration tab (see section 2.1.2).

Visualization	Other
Function	Energy Monitor
Indicator Icon	 Energy Monitor
Default Energy Monitor Tab	Global Tab
Protect	<input checked="" type="radio"/> No <input type="radio"/> Yes

Figure 95. Energy Monitor

- **Indicator Icon** [[Energy Monitor](#)]: allows choosing the corresponding icon for this screen control.
- **Default Energy Monitor Tab** [[Global Tab](#) / [Individual Consumption Tab 1](#) / ... / [Individual Consumption Tab 4](#)]: allows choosing which tab is going to be displayed by default when energy monitor is opened.

### 2.2.2.1.5.10 Keypad

This control allows sending numerical codes of between 1 and 14 digits through the object “[Ci] Keypad – Control”. When accessing the panel, a numeric keypad is displayed to enter the code and the buttons to delete and send the code. In case **Show Current Code** parameter is enabled, the current code will be displayed both in the box and when opening the panel.

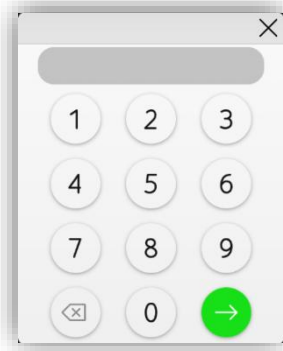

Figure 96. Numeric Keypad panel

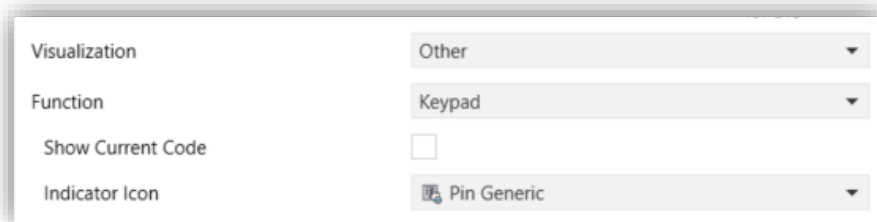

Figure 97. Keypad configuration

- **Show Current Code** [*disabled / enabled*]: enables the object “[Ci] Keypad – Status” to display the last received code in the box.

#### 2.2.2.1.5.11 *Multimedia*

This kind of control sends playback control commands to other devices and is configured with the following parameters:

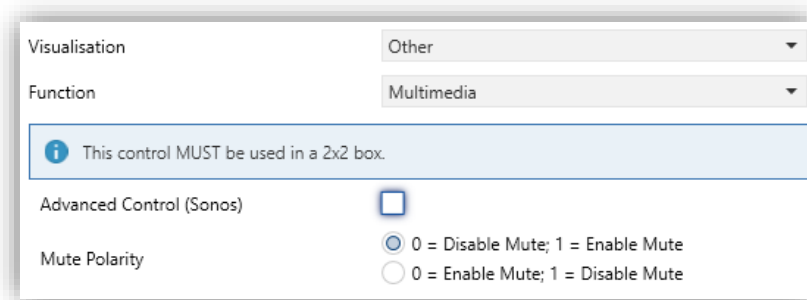

Figure 98. Multimedia control configuration

- **Advanced control (Sonos)** [*disabled / enabled*]: defines whether multimedia control will be basic or whether it controls Sonos devices. If enabled, the following parameter is displayed:

- **Sonos Instance Associated** [1... 4]: sets the instance to be managed from the control.
- **Mute Polarity** [0 = Disable Mute; 1 = Enable Mute / 0 = Enable Mute; 1 = Disable Mute]: sets the polarity of the mute object for basic multimedia control.

**Important:** *these kinds of controls are only visible if they are configured with a size of 2x2 (see section 2.2.1.3 for more information). This 2x2 box will be compatible with the remote control.*

#### 2.2.2.1.5.11.1 Multimedia basic control

---

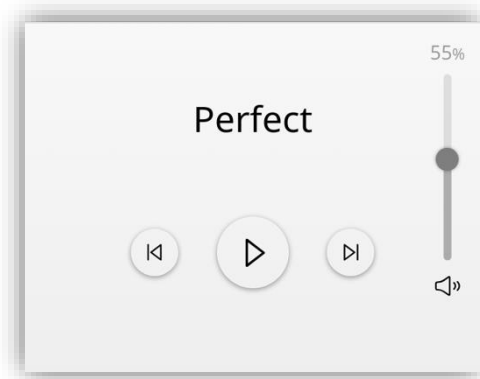

Figure 99. Multimedia basic control

Control playback on other devices by sending the following objects:

- “[Ci] Multimedia – Play/Pause”
- “[Ci] Multimedia – Volume”
- “[Ci] Multimedia – Mute”
- “[Ci] Multimedia – Skip”

It also has the object “[Ci] Multimedia – Song” which modifies the song title using the value received from another device.

#### 2.2.2.1.5.11.2 Advanced Control (Sonos)

---

If the **Advanced Control (Sonos)** parameter is enabled, this control becomes associated with one of the instances enabled in the “Sonos” tab (see section 2.1.9).

From here, it is possible to control actions that will be automatically sent to the speaker associated with that instance.



Figure 100. Advanced Control (Sonos)

The button  opens the speaker/zone selection menu. The selected speaker/zone will be associated with the Sonos instance configured for this control, so that all commands and statuses will be sent through the objects of that instance.

The button  opens the playlist selection panel. First, the lists that have been added with the “Add to Sonos playlist” option are displayed, followed by those that have been added as “Sonos Favourites”. The order of each group will be from the most recent to the oldest.

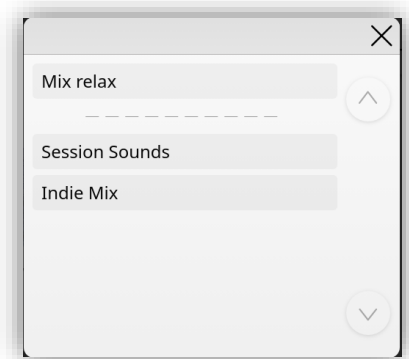

Figure 101. Playlist selection panel

The other buttons available on the control will be play/pause, skip song, shuffle mode, repeat mode, and full volume control. In addition, information such as the song title, artist, and album cover will be displayed.

**Note:** *the buttons available on the control will depend on the buttons available in the Sonos app, so if radio is playing, for example, it will not be possible to change songs or activate shuffle or repeat mode.*

## 2.3 LOGIC FUNCTIONS

---

RemoteBOX allows to perform numeric and binary operations to incoming values received from the KNX bus, and to send the results through other communication objects specifically enabled for this purpose.

Up to 10 different and independent functions can be implemented, each of them entirely customisable and consisting in up to 4 consecutive operations each one.

The execution of each function can depend on a configurable condition, which will be evaluated every time the function is triggered through specific, parameterisable communication objects. The result after executing the operations of the function can also be evaluated according to certain conditions and afterwards sent (or not) to the KNX bus, which can be done every time the function is executed, periodically or only when the result differs from the last one.

Please refer to the “**Logic Functions**” user manual, available within the device product section at the Zennio homepage, [www.zennio.com](http://www.zennio.com), for detailed information about the functionality and the configuration of the related parameters.

## ANNEX I. REMOTE CONTROL VIA IP

RemoteBOX feature an Ethernet interface that makes it possible to perform actions over the device by means of remote IP applications. This brings the option to control its functions analogously as if the device were actually being controlled on site.

### CONFIGURATION

Before being able to control the device remotely, it is necessary to make a previous pairing between the remote application and the device. This pairing can be done in different ways:

- In the **configuration page**, where the pairing box is located.

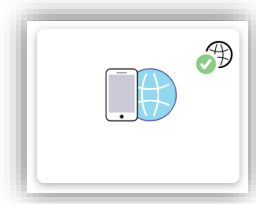

Figure 102. Device Pairing box

In the upper right corner there is a service state indicator. This indicator will be automatically updated if the state changes.

Service state	Icon
The device has not license for remote control	
No network connection	
The service is not available	
Link and service OK	
Remote control in process (remote device currently connected)	

Table 10. Service States

- From the **Webserver Tools** Remote Control page (please refer to the specific “**Webserver Tools**” user manual, available in the product section of the Zennio web portal [www.zennio.com](http://www.zennio.com) for more information).
- Enabling **pairing objects**.
- Enabling **local pairing** and searching the device from Zennio Remote.

**Note:** *pairing multiple devices to a particular remote application is possible, as well as pairing a particular device to multiple remote applications.*

## PAIRING FROM CONFIGURATION PAGE

---

Once the device has been configured as described, pressing on the Device Pairing box will bring up a pop-up window similar to Figure 103.

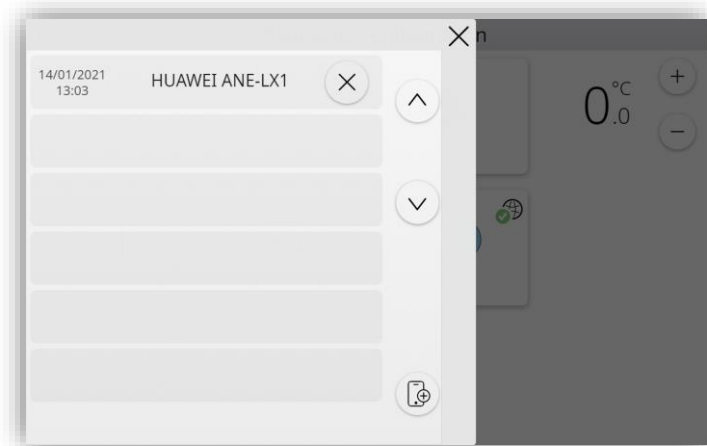

**Figure 103.** Pop-up to pairing device

In case there is any communication error with the server this pop-up will show an error icon, allowing only to close the tab.

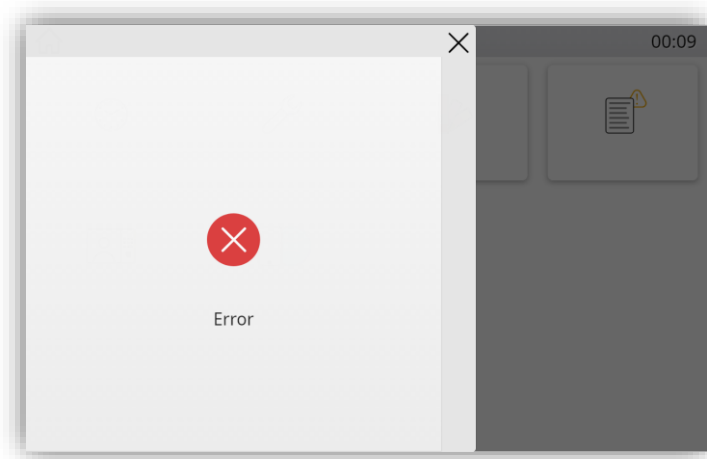



Figure 104. Communication error

This tab displayed:

- **Paired devices**, with the **time and date** of the last connection for each device and a **button to remove** the pairing with that device by long press.
- **Pairing button** : clicking on this button generates an **alphanumeric pairing code** together with a QR code. This code, which will be active for the time configured in **Pairing Code Expiration Time** (see section 2.1.2), has to be entered in the remote application to perform the pairing.

This pairing process will only need to be done once.

On the right side of the pop-up there are arrows to scroll through the list of paired devices.

## OBJECT PAIRING

---

When pairing objects are enabled, the “[Remote Control] Request Pairing” object will be displayed to initiate pairing. When enabled, the device will send a code via the “[Remote Control] Pairing Code” object to be used in the remote control application to pair.

The object “[Remote Control] Delete All Pairings” will also be displayed, which deletes all pairings that the device currently has.

## PUSH NOTIFICATIONS

---

RemoteBOX incorporates the “push” notification function, which consists in notifying the mobile devices (no matter if the remote control application has been started or not) about alarm events:

- **Alarm activation:** a box that has been assigned the Alarm function has either received the alarm trigger value from the KNX bus, or exceeded the cyclical monitoring period.
- **Alarm confirmation:** a box with an active alarm has been acknowledged by the user.
- **Alarm deactivation:** a box that has already been acknowledged by the user has also received the no-alarm trigger value. Therefore, the alarm has been deactivated and acknowledged.

The above notifications are shown on the mobile device (unless “push” notifications are disabled by the operating system of the device, depending on the user settings) according to the label assigned to the involved alarm box.

**Note:** *Zennio Avance y Tecnología S.L. does not accept any responsibility for losses of “push” messages due to network, hardware or software failures of any kind.*

## REMOTE APPLICATIONS

---

For instructions on configuring and using the available remote applications, please refer to the “Zennio Remote” specific document, available at the Zennio home site: [www.zennio.com](http://www.zennio.com).

## ANNEX II. GRAPHS

RemoteBOX can display graphs with a history of the values received through the indicator objects of the different boxes. The boxes that have this functionality enabled will have a button on the top left to access the graph.

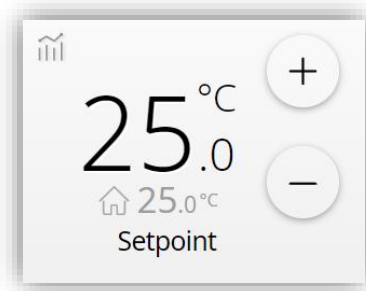
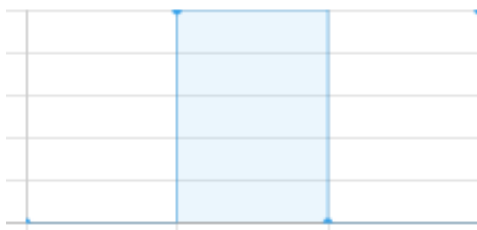

Figure 105. Control with enabled graph

The graphs displayed may have different types of representation depending on the type of data to be displayed:

● Switch:



● Curve:

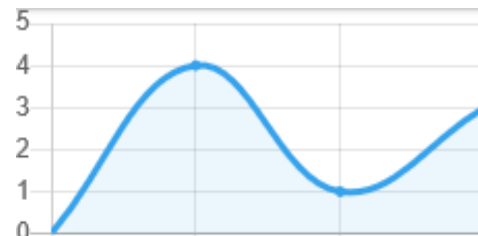

● Straight:

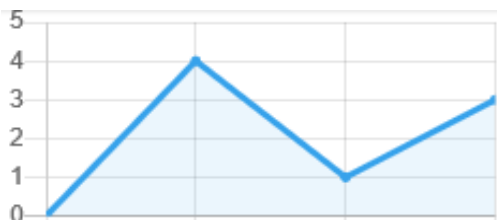

● Step:

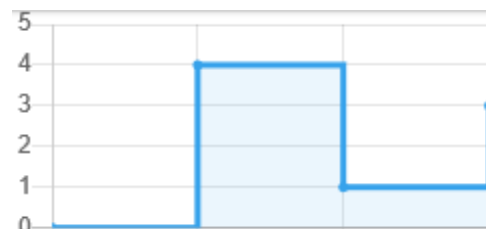

Depending on the type of control parameterised, it will be possible to enable or disable the option of displaying its graph. The following table shows the controls that allow graphs to be displayed and the type of representation available for each of them:

Type of control	Function	Type of representation available
Indicator	Binary	Switching graph
	Integer	Line graph [curve/straight/step]
	Percentage	Line graph [curve/straight/step]
	Float	Line graph [curve/straight/step]
	Temperature	Line graph [curve/straight/step]
1-Button Control	Switch	Switching graph
	Two Objects (Short Press/Long Press)	Switching graph
2-Button Control	Switch	Switching graph
	Switch + Indicator (counter)	Line graph [curve/straight/step]
	Switch + Indicator (scaling)	Line graph [curve/straight/step]
	Switch + Indicator (float)	Line graph [curve/straight/step]
	Switch + Indicator (temperature)	Line graph [curve/straight/step]
	Two Objects (Short Press/Long Press)	Switching graph
	Counter	Line graph [curve/straight/step]
	Scaling	Line graph [curve/straight/step]
	Float	Line graph [curve/straight/step]
	Shutter	Line graph [step]
Dimmer	Line graph [step]	
Climate Control	Temperature Setpoint	Line graph [Setpoint: step; Real: curve]
	Fan (Scaling)	Line graph [step]

Table 11. Controls allowing graphs

## GRAPH PANEL

The graph panel has the following elements:

- **Graph:** this will be the main element where the recorded data is displayed. The x-axis will correspond to the period shown and the y-axis will be adjusted depending on the maximum and minimum value shown in that period. In addition, the information of the period being displayed will be shown at the top right.
- **Graph comparison button:** this button opens an additional menu for comparing two graphs. In this menu, it is possible to select the control to compare, allowing only the comparison of data of the same type. After selecting the desired control, a legend will be displayed to indicate which control each graph corresponds to.
- **Note:** *in the case of climate graphs with setpoint and actual temperature, the comparison will always be made using the actual temperature.*

- **Navigation buttons:** at the bottom, the buttons to navigate through the graph will be displayed to select the period to be shown. The zoom level is changed by enabling/disabling each checkbox. A simple example of navigation is shown below:

*To access the graph of 29 April 2022, it will be necessary to uncheck the time checkbox and set 29 April 2022 by using the arrows.*



Figure 106. Graph panel

For more precise information, a tooltip will be displayed when clicking on any of the recorded data. The exact time of the received data and the recorded value are indicated inside.

## ZOOM LEVELS

Within the panel it is possible to access different zoom levels by enabling and disabling the checkboxes in the navigation area:

- **Day and hour levels:** these two levels show the data recorded with a zoom level of one day or one hour.
- **Month and year levels:** these two zoom levels show the averages, maximums and minimums of the data recorded each day or each month.
- **Global level:** when all the checkboxes are unchecked, a global view is displayed showing the monthly averages of the last 5 years recorded.

**Note:** *in the case of switching or step type graphs only the day and hour levels will be available.*

## DATA MANAGEMENT

---

The recorded **data is stored** in memory every **5 minutes** (only if the device has a valid time). If the number of data received in that period exceeds 4, the device performs a filtering by selecting the 4 values that will best define the graph.

There are some cases where the device can make a partial **deletion** of the recorded data:

- When a change of date and time is made and the device has data stored from later dates than the one established, these will be deleted to avoid having duplicate data at the same time. Data before that date will remain stored.
- When the memory is full, the oldest 30 days that have been recorded will be deleted.

The recorded data can be deleted or downloaded from the web server. For further information, please refer to the “**Webserver Tools**” manual (available in the product section in Zennio web portal, [www.zennio.com](http://www.zennio.com)).

## ANNEX III. ENERGY MONITOR CONFIGURATION

In order to make use of the energy monitor functionality, it is necessary to have a consumption meter to send the measurements, for example KES Plus. The power and energy objects of the consumption meter will be associated with the corresponding power and energy objects of the energy monitor.

### Notes:

- *The energy objects must be linked to a total register, so that the received energy value is always increasing and does not reset.*
- *It is recommended to have the **Automatic Read Requests** parameter enabled to ensure the correct value at the end of each period.*

## INSTALLATION

This section defines the points of the installation where the measurements must be taken in order to have a correct operation of the global tab of the energy monitor. Figure 107 shows the diagram of an installation with solar panels and battery:

- Point 1 measures the energy imported and exported.
- Point 2 measures the energy produced at the inverter output.
- Point 3 measures the energy consumed in the house.

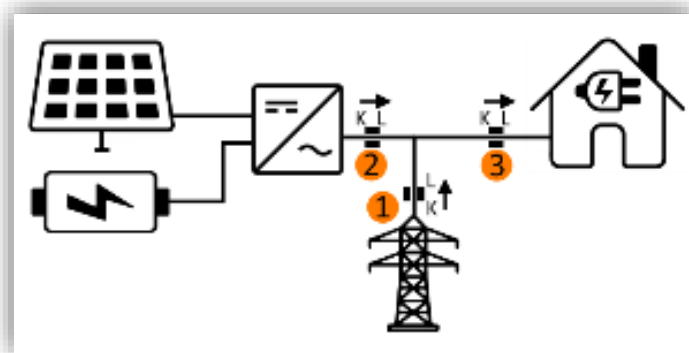

Figure 107. Installation diagram with solar panels and battery

Depending on the type of installation, there may be 1, 2 or 3 measurement points:

- **Installation without solar panels or battery:** only point 1 shown in the diagram in Figure 107.
- **Installation with solar panels:** in this case, can be 2 or 3 measurement points. The ideal case would be to have all 3 points in the diagram, but in some cases point 3 is not accessible and the monitor can be configured with only points 1 and 2.
- **Installation with solar panels and battery (2 inverters):** in this case, the measurement point for the solar panels is divided into two, with one point behind the panel inverter and another behind the battery inverter.

## ANNEX IV. COMMUNICATION OBJECTS

- “Functional range” shows the values that, with independence of any other values permitted by the bus according to the object size, may be of any use or have a particular meaning because of the specifications or restrictions from both the KNX standard or the application program itself.

Number	Size	I/O	Flags	Data type (DPT)	Functional Range	Name	Function
1	3 Bytes	O	<b>C R - T U</b>	DPT_TimeOfDay	00:00:00 - 23:59:59	[General] Time of Day	Current Time
2	3 Bytes	O	<b>C R - T U</b>	DPT_Date	01/01/1990 - 31/12/2089	[General] Date	Current Date
3	1 Byte	O	<b>C - - T -</b>	DPT_SceneControl	0-63; 128-191	[General] Scenes: Send	0-63/128-191 (Run/Save Scene 1-64)
4	1 Byte	I	<b>C - W - -</b>	DPT_SceneNumber	0 - 63	[General] Scenes: Receive	0-63 (Run Scene 1-64)
5	1 Bit	I	<b>C - W - -</b>	DPT_State	0/1	[General] Activity	0 = Inactivity; 1 = Activity
6	1 Byte	I	<b>C - W - -</b>	Locale Enumeration	0 - 5	[General] Localisation - Select	0 = Main; 1 = Conf. 2; ...; 4 = Conf. 5
7	4 Bytes	I	<b>C - W - -</b>	1.xxx	0/1	[General] Localisation - Select	Locale Selection Through ISO 639-1/ISO 3166-1 Four Letters Code
8	2 Bytes	I	<b>C - W - -</b>	DPT_LanguageCodeAlpha2_ASCII		[General] Translations - Select	Language Selection Through ISO 639-1 Two Letters Code
18	1 Bit	I	<b>C - W T U</b>	DPT_Switch	0/1	[General] Temperature Scale	0 = °C; 1 = °F
19, 25, 31, 37, 43, 49	1 Bit	I	<b>C - W - -</b>	DPT_Switch	0/1	[General][Pop-Up x] 1 Bit	0 = Hide Pop-Up; 1 = Show Pop-Up
	1 Bit	I	<b>C - W - -</b>	DPT_Switch	0/1	[General][Pop-Up x] 1 Bit	0 = Show Pop-Up; 1 = Hide Pop-Up
20, 26, 32, 38, 44, 50	1 Byte	I	<b>C - W - -</b>	DPT_Value_1_Ucount	0 - 255	[General][Pop-Up x] 1 Byte	Hide/Show Pop-Up
21, 22, 23, 24, 27, 28, 29, 30, 33, 34, 35, 36, 39, 40, 41, 42, 45, 46, 47, 48, 51, 52, 53, 54	14 Bytes	I	<b>C - W - -</b>	DPT_String_UTF-8		[General][Pop-Up x] Line x	Text to Show on the Display at Line x
55	1 Byte	I	<b>C - W T -</b>	1.xxx	0/1	[Profile] Theme	0 = Light; 1 = Dark
56	1 Byte	I	<b>C - W T -</b>	DPT_Scaling	0% - 100%	[Profile] Volume	0% ... 100%
256	4 Bytes	I	<b>C - W T U</b>	DPT_ActiveEnergy	0 - 2147483647	[EM] Consumed Energy	W·h
	4 Bytes	I	<b>C - W T U</b>	DPT_ActiveEnergy_kWh	0 - 2147483647	[EM] Consumed Energy	kW·h
257	4 Bytes	I	<b>C - W T U</b>	DPT_ActiveEnergy	0 - 2147483647	[EM] Imported Energy	W·h
	4 Bytes	I	<b>C - W T U</b>	DPT_ActiveEnergy_kWh	0 - 2147483647	[EM] Imported Energy	kW·h

258	4 Bytes	I	C - W T U	DPT_ActiveEnergy	0 - 2147483647	[EM] Exported Energy	W·h
	4 Bytes	I	C - W T U	DPT_ActiveEnergy_kWh	0 - 2147483647	[EM] Exported Energy	kW·h
259	4 Bytes	I	C - W T U	DPT_ActiveEnergy	0 - 2147483647	[EM] Produced Energy	W·h
	4 Bytes	I	C - W T U	DPT_ActiveEnergy_kWh	0 - 2147483647	[EM] Produced Energy	kW·h
260	4 Bytes	I	C - W T U	DPT_ActiveEnergy	0 - 2147483647	[EM] Battery Output Energy	W·h
	4 Bytes	I	C - W T U	DPT_ActiveEnergy_kWh	0 - 2147483647	[EM] Battery Output Energy	kW·h
261	4 Bytes	I	C - W T U	DPT_ActiveEnergy_kWh	0 - 2147483647	[EM] Battery Input Energy	kW·h
	4 Bytes	I	C - W T U	DPT_ActiveEnergy	0 - 2147483647	[EM] Battery Input Energy	W·h
262	4 Bytes	I	C - W - -	DPT_Value_Power	-3.4E+38 W - 3.4E+38 W	[EM] Consumed Power	W
	2 Bytes	I	C - W - -	DPT_Power	-671088.64 - 670433.28 kW	[EM] Consumed Power	kW
263	4 Bytes	I	C - W - -	DPT_Value_Power	-3.4E+38 W - 3.4E+38 W	[EM] Imported/Exported Power	W (> 0 = Imported; < 0 = Exported)
	2 Bytes	I	C - W - -	DPT_Power	-671088.64 - 670433.28 kW	[EM] Imported/Exported Power	kW (> 0 = Imported; < 0 = Exported)
	4 Bytes	I	C - W - -	DPT_Value_Power	-3.4E+38 W - 3.4E+38 W	[EM] Imported Power	W
	2 Bytes	I	C - W - -	DPT_Power	-671088.64 - 670433.28 kW	[EM] Imported Power	kW
264	4 Bytes	I	C - W - -	DPT_Value_Power	-3.4E+38 W - 3.4E+38 W	[EM] Exported Power	W
	2 Bytes	I	C - W - -	DPT_Power	-671088.64 - 670433.28 kW	[EM] Exported Power	kW
265	4 Bytes	I	C - W - -	DPT_Value_Power	-3.4E+38 W - 3.4E+38 W	[EM] Produced Power	W
	2 Bytes	I	C - W - -	DPT_Power	-671088.64 - 670433.28 kW	[EM] Produced Power	kW
266	4 Bytes	I	C - W - -	DPT_Value_Power	-3.4E+38 W - 3.4E+38 W	[EM] Battery Input/Output Power	W (> 0 = Output; < 0 = Input)
	2 Bytes	I	C - W - -	DPT_Power	-671088.64 - 670433.28 kW	[EM] Battery Input/Output Power	kW (> 0 = Output; < 0 = Input)
	2 Bytes	I	C - W - -	DPT_Power	-671088.64 - 670433.28 kW	[EM] Battery Input Power	kW
	4 Bytes	I	C - W - -	DPT_Value_Power	-3.4E+38 W - 3.4E+38 W	[EM] Battery Input Power	W

267	4 Bytes	I	C - W - -	DPT_Value_Power	-3.4E+38 W - 3.4E+38 W	[EM] Battery Output Power	W
	2 Bytes	I	C - W - -	DPT_Power	-671088.64 - 670433.28 kW	[EM] Battery Output Power	kW
268	1 Byte	I	C - W - -	DPT_Scaling	0% - 100%	[EM] Battery Percentage	0% ... 100%
269, 281, 293, 305	4 Bytes	I	C - W T U	DPT_ActiveEnergy	0 - 2147483647	[EM][ICx][D1] Consumed Energy	W·h
	4 Bytes	I	C - W T U	DPT_ActiveEnergy_kWh	0 - 2147483647	[EM][ICx][D1] Consumed Energy	kW·h
270, 282, 294, 306	4 Bytes	I	C - W T U	DPT_Value_Power	-3.4E+38 W - 3.4E+38 W	[EM][ICx][D1] Consumed Power	W
	2 Bytes	I	C - W T U	DPT_Power	-671088.64 - 670433.28 kW	[EM][ICx][D1] Consumed Power	kW
271, 283, 295, 307	4 Bytes	I	C - W T U	DPT_ActiveEnergy	0 - 2147483647	[EM][ICx][D2] Consumed Energy	W·h
	4 Bytes	I	C - W T U	DPT_ActiveEnergy_kWh	0 - 2147483647	[EM][ICx][D2] Consumed Energy	kW·h
272, 284, 296, 308	4 Bytes	I	C - W T U	DPT_Value_Power	-3.4E+38 W - 3.4E+38 W	[EM][ICx][D2] Consumed Power	W
	2 Bytes	I	C - W T U	DPT_Power	-671088.64 - 670433.28 kW	[EM][ICx][D2] Consumed Power	kW
273, 285, 297, 309	4 Bytes	I	C - W T U	DPT_ActiveEnergy	0 - 2147483647	[EM][ICx][D3] Consumed Energy	W·h
	4 Bytes	I	C - W T U	DPT_ActiveEnergy_kWh	0 - 2147483647	[EM][ICx][D3] Consumed Energy	kW·h
274, 286, 298, 310	4 Bytes	I	C - W T U	DPT_Value_Power	-3.4E+38 W - 3.4E+38 W	[EM][ICx][D3] Consumed Power	W
	2 Bytes	I	C - W T U	DPT_Power	-671088.64 - 670433.28 kW	[EM][ICx][D3] Consumed Power	kW
275, 287, 299, 311	4 Bytes	I	C - W T U	DPT_ActiveEnergy	0 - 2147483647	[EM][ICx][D4] Consumed Energy	W·h
	4 Bytes	I	C - W T U	DPT_ActiveEnergy_kWh	0 - 2147483647	[EM][ICx][D4] Consumed Energy	kW·h
276, 288, 300, 312	4 Bytes	I	C - W T U	DPT_Value_Power	-3.4E+38 W - 3.4E+38 W	[EM][ICx][D4] Consumed Power	W
	2 Bytes	I	C - W T U	DPT_Power	-671088.64 - 670433.28 kW	[EM][ICx][D4] Consumed Power	kW
277, 289, 301, 313	4 Bytes	I	C - W T U	DPT_ActiveEnergy	0 - 2147483647	[EM][ICx][D5] Consumed Energy	W·h
	4 Bytes	I	C - W T U	DPT_ActiveEnergy_kWh	0 - 2147483647	[EM][ICx][D5] Consumed Energy	kW·h
278, 290, 302, 314	4 Bytes	I	C - W T U	DPT_Value_Power	-3.4E+38 W - 3.4E+38 W	[EM][ICx][D5] Consumed Power	W

	2 Bytes	I	C - W T U	DPT_Power	-671088.64 - 670433.28 kW	[EM][ICx][D5] Consumed Power	kW
279, 291, 303, 315	4 Bytes	I	C - W T U	DPT_ActiveEnergy	0 - 2147483647	[EM][ICx][D6] Consumed Energy	W·h
	4 Bytes	I	C - W T U	DPT_ActiveEnergy_kWh	0 - 2147483647	[EM][ICx][D6] Consumed Energy	kW·h
280, 292, 304, 316	4 Bytes	I	C - W T U	DPT_Value_Power	-3.4E+38 W - 3.4E+38 W	[EM][ICx][D6] Consumed Power	W
	2 Bytes	I	C - W T U	DPT_Power	-671088.64 - 670433.28 kW	[EM][ICx][D6] Consumed Power	kW
327, 328, 329, 330, 331, 332, 333, 334, 335, 336, 337, 338, 339, 340, 341, 342, 343, 344, 345, 346, 347, 348, 349, 350, 351, 352, 353, 354, 355, 356	1 Bit	I/O	C R W T U	DPT_Enable	0/1	[Sx] Scheduler - Enable	0 = Disable; 1 = Enable
357	1 Bit	I	C - W T -	DPT_Ack	0/1	[Remote Control] Request Pairing	1 = Request Pairing
358	1 Bit	I	C - W T -	DPT_Ack	0/1	[Remote Control] Delete All Pairings	1 = Delete Pairings
359	14 Bytes	O	C - - T -	DPT_String_UTF-8		[Remote Control] Pairing Code	Text String
360	1 Bit	I	C - W - -	DPT_Trigger	0/1	[Sonos] Trigger Sound 1	Trigger Sound
361	1 Bit	I	C - W - -	DPT_Trigger	0/1	[Sonos] Trigger Sound 2	Trigger Sound
362	1 Bit	I	C - W - -	DPT_Trigger	0/1	[Sonos] Trigger Sound 3	Trigger Sound
363, 378, 393, 408	1 Bit	I	C - W - -	DPT_Trigger	0/1	[Sx] Trigger Sound - Control	Trigger Sound
364, 379, 394, 409	1 Bit	I	C - W - -	DPT_Start	0/1	[Sx] Play/Pause - Control	0 = Pause; 1 = Play
365, 380, 395, 410	1 Bit	O	C R - T -	DPT_Start	0/1	[Sx] Play/Pause - Status	0 = Pause; 1 = Play
366, 381, 396, 411	1 Bit	I	C - W - -	DPT_Step	0/1	[Sx] Skip - Control	0 = Backward; 1 = Forward
367, 382, 397, 412	1 Bit	I	C - W - -	DPT_Enable	0/1	[Sx] Mute - Control	0 = Disable Mute; 1 = Enable Mute
368, 383, 398, 413	1 Bit	O	C R - T -	DPT_Enable	0/1	[Sx] Mute - Status	0 = Disable Mute; 1 = Enable Mute
369, 384, 399, 414	1 Bit	I	C - W - -	DPT_Enable	0/1	[Sx] Shuffle - Control	0 = Disable Shuffle; 1 = Enable Shuffle
370, 385, 400, 415	1 Bit	O	C R - T -	DPT_Enable	0/1	[Sx] Shuffle - Status	0 = Disable Shuffle; 1 = Enable Shuffle
371, 386, 401, 416	1 Bit	I	C - W - -	DPT_Enable	0/1	[Sx] Repeat - Control	0 = Disable Repeat; 1 = Enable Repeat
372, 387, 402, 417	1 Bit	O	C R - T -	DPT_Enable	0/1	[Sx] Repeat - Status	0 = Disable Repeat; 1 = Enable Repeat
373, 388, 403, 418	1 Byte	I	C - W - -	DPT_Scaling	0% - 100%	[Sx] Volume - Control	0% ... 100%
374, 389, 404, 419	1 Byte	O	C R - T -	DPT_Scaling	0% - 100%	[Sx] Volume - Status	0% ... 100%
375, 390, 405, 420	1 Byte	I	C - W - -	DPT_Value_1_Ucount	0 - 255	[Sx] Preset - Control	0 = First preset; 1 = Second preset; 2 = Third preset; ...
376, 391, 406, 421	14 Bytes	O	C R - T -	DPT_String_UTF-8		[Sx] Song - Status	Text String

377, 392, 407, 422	14 Bytes	O	<b>C R - T -</b>	DPT_String_UTF-8		[Sx] Artist - Status	Text String
423, 425, 427, 429, 431, 433, 435, 437, 439, 441, 443, 445, 447, 449, 451, 453, 455, 457, 459, 461, 463, 465, 467, 469, 471, 473, 475, 477, 479, 481, 483, 485, 487, 489, 491, 493, 495, 497, 499, 501, 503, 505, 507, 509, 511, 513, 515, 517, 519, 521, 523, 525, 527, 529, 531, 533, 535, 537, 539, 541, 543, 545, 547, 549, 551, 553, 555, 557, 559, 561	1 Bit	I	<b>C - W - U</b>	DPT_Alarm	0/1	[Evx][x] Alarm - Trigger	Trigger: 0
	1 Bit	I	<b>C - W - U</b>	DPT_Alarm	0/1	[Evx][x] Alarm - Trigger	Trigger: 1
	1 Bit	I	<b>C - W - U</b>	DPT_Alarm	0/1	[Evx][x] Low Battery	0 = No Alarm; 1 = Alarm
	1 Bit	I	<b>C - W - -</b>	DPT_Trigger	0/1	[Evx][x] Heartbeat	Receiving of '1' Periodically
424, 426, 428, 430, 432, 434, 436, 438, 440, 442, 444, 446, 448, 450, 452, 454, 456, 458, 460, 462, 464, 466, 468, 470, 472, 474, 476, 478, 480, 482, 484, 486, 488, 490, 492, 494, 496, 498, 500, 502, 504, 506, 508, 510, 512, 514, 516, 518, 520, 522, 524, 526, 528, 530, 532, 534, 536, 538, 540, 542, 544, 546, 548, 550, 552, 554, 556, 558, 560, 562	1 Bit	I	<b>C - W T U</b>	DPT_Ack	0/1	[Evx][x] Alarm - Confirmation	0 = No Action; 1 = Confirm
563, 564, 565, 566, 567, 568, 569, 570	1 Bit	I	<b>C - W - -</b>	DPT_Switch	0/1	[Config.][Bx] Show/Hide Box	0 = Hide Box; 1 = Show Box
571, 591, 611, 631, 651, 671, 691, 711, 731, 751, 771, 791	1 Bit	I	<b>C - W - -</b>	DPT_Switch	0/1	[Px][B1] Show/Hide Box	0 = Hide Box; 1 = Show Box
572, 592, 612, 632, 652, 672, 692, 712, 732, 752, 772, 792	1 Bit	I	<b>C - W - -</b>	DPT_Switch	0/1	[Px][B2] Show/Hide Box	0 = Hide Box; 1 = Show Box
573, 593, 613, 633, 653, 673, 693, 713, 733, 753, 773, 793	1 Bit	I	<b>C - W - -</b>	DPT_Switch	0/1	[Px][B3] Show/Hide Box	0 = Hide Box; 1 = Show Box
574, 594, 614, 634, 654, 674, 694, 714, 734, 754, 774, 794	1 Bit	I	<b>C - W - -</b>	DPT_Switch	0/1	[Px][B4] Show/Hide Box	0 = Hide Box; 1 = Show Box
575, 595, 615, 635, 655, 675, 695, 715, 735, 755, 775, 795	1 Bit	I	<b>C - W - -</b>	DPT_Switch	0/1	[Px][B5] Show/Hide Box	0 = Hide Box; 1 = Show Box

576, 596, 616, 636, 656, 676, 696, 716, 736, 756, 776, 796	1 Bit	I	C - W - -	DPT_Switch	0/1	[Px][B6] Show/Hide Box	0 = Hide Box; 1 = Show Box
577, 597, 617, 637, 657, 677, 697, 717, 737, 757, 777, 797	1 Bit	I	C - W - -	DPT_Switch	0/1	[Px][B7] Show/Hide Box	0 = Hide Box; 1 = Show Box
578, 598, 618, 638, 658, 678, 698, 718, 738, 758, 778, 798	1 Bit	I	C - W - -	DPT_Switch	0/1	[Px][B8] Show/Hide Box	0 = Hide Box; 1 = Show Box
579, 599, 619, 639, 659, 679, 699, 719, 739, 759, 779, 799	1 Bit	I	C - W - -	DPT_Switch	0/1	[Px][B9] Show/Hide Box	0 = Hide Box; 1 = Show Box
580, 600, 620, 640, 660, 680, 700, 720, 740, 760, 780, 800	1 Bit	I	C - W - -	DPT_Switch	0/1	[Px][B10] Show/Hide Box	0 = Hide Box; 1 = Show Box
581, 601, 621, 641, 661, 681, 701, 721, 741, 761, 781, 801	1 Bit	I	C - W - -	DPT_Switch	0/1	[Px][B11] Show/Hide Box	0 = Hide Box; 1 = Show Box
582, 602, 622, 642, 662, 682, 702, 722, 742, 762, 782, 802	1 Bit	I	C - W - -	DPT_Switch	0/1	[Px][B12] Show/Hide Box	0 = Hide Box; 1 = Show Box
583, 603, 623, 643, 663, 683, 703, 723, 743, 763, 783, 803	1 Bit	I	C - W - -	DPT_Switch	0/1	[Px][B13] Show/Hide Box	0 = Hide Box; 1 = Show Box
584, 604, 624, 644, 664, 684, 704, 724, 744, 764, 784, 804	1 Bit	I	C - W - -	DPT_Switch	0/1	[Px][B14] Show/Hide Box	0 = Hide Box; 1 = Show Box
585, 605, 625, 645, 665, 685, 705, 725, 745, 765, 785, 805	1 Bit	I	C - W - -	DPT_Switch	0/1	[Px][B15] Show/Hide Box	0 = Hide Box; 1 = Show Box
586, 606, 626, 646, 666, 686, 706, 726, 746, 766, 786, 806	1 Bit	I	C - W - -	DPT_Switch	0/1	[Px][B16] Show/Hide Box	0 = Hide Box; 1 = Show Box
587, 607, 627, 647, 667, 687, 707, 727, 747, 767, 787, 807	1 Bit	I	C - W - -	DPT_Switch	0/1	[Px][B17] Show/Hide Box	0 = Hide Box; 1 = Show Box
588, 608, 628, 648, 668, 688, 708, 728, 748, 768, 788, 808	1 Bit	I	C - W - -	DPT_Switch	0/1	[Px][B18] Show/Hide Box	0 = Hide Box; 1 = Show Box
589, 609, 629, 649, 669, 689, 709, 729, 749, 769, 789, 809	1 Bit	I	C - W - -	DPT_Switch	0/1	[Px][B19] Show/Hide Box	0 = Hide Box; 1 = Show Box
590, 610, 630, 650, 670, 690, 710, 730, 750, 770, 790, 810	1 Bit	I	C - W - -	DPT_Switch	0/1	[Px][B20] Show/Hide Box	0 = Hide Box; 1 = Show Box

811, 817, 823, 829, 835, 841, 847, 853, 859, 865, 871, 877, 883, 889, 895, 901, 907, 913, 919, 925, 931, 937, 943, 949, 955, 961, 967, 973, 979, 985, 991, 997, 1003, 1009, 1015, 1021, 1027, 1033, 1039, 1045, 1051, 1057, 1063, 1069, 1075, 1081, 1087, 1093, 1099, 1105, 1111, 1117, 1123, 1129, 1135, 1141, 1147, 1153, 1159, 1165, 1171, 1177, 1183, 1189, 1195, 1201, 1207, 1213, 1219, 1225, 1231, 1237, 1243, 1249, 1255, 1261, 1267, 1273, 1279, 1285, 1291, 1297, 1303, 1309, 1315, 1321, 1327, 1333, 1339, 1345, 1351, 1357, 1363, 1369, 1375, 1381, 1387, 1393, 1399, 1405, 1411, 1417, 1423, 1429, 1435, 1441, 1447, 1453, 1459, 1465, 1471, 1477, 1483, 1489, 1495, 1501, 1507, 1513, 1519, 1525, 1531, 1537, 1543, 1549, 1555, 1561, 1567, 1573, 1579, 1585, 1591, 1597, 1603, 1609, 1615, 1621, 1627, 1633, 1639, 1645, 1651, 1657, 1663, 1669, 1675, 1681, 1687, 1693, 1699, 1705, 1711, 1717, 1723, 1729, 1735, 1741, 1747, 1753, 1759, 1765, 1771, 1777, 1783, 1789, 1795, 1801, 1807, 1813, 1819, 1825, 1831, 1837, 1843, 1849, 1855, 1861, 1867, 1873, 1879, 1885	1 Bit	I	C - W T U	DPT_Switch	0/1	[Cx][x] Switch - Status	1-Bit Indicator
	1 Byte	I	C - W T U	DPT_Value_1_Ucount	0 - 255	[Cx][x] Enumeration - Status	0 ... 255
	1 Byte	I	C - W T U	DPT_Value_1_Count	-128 - 127	[Cx][x] Integer - 1-Byte Signed Status	-128 ... 127
	2 Bytes	I	C - W T U	DPT_Value_2_Count	-32768 - 32767	[Cx][x] Integer - 2-Byte Signed Status	-32768 ... 32767
	1 Byte	I	C - W T U	DPT_Value_1_Ucount	0 - 255	[Cx][x] Integer - 1-Byte Unsigned Status	0 ... 255
	2 Bytes	I	C - W T U	DPT_Value_2_Ucount	0 - 65535	[Cx][x] Integer - 2-Byte Unsigned Status	0 ... 65535
	1 Byte	I	C - W T U	DPT_Scaling	0% - 100%	[Cx][x] Percentage - Status	0% ... 100%
	2 Bytes	I	C - W T U	9.xxx	-671088.64 - 670433.28	[Cx][x] Float - 2-Byte Status	-671088.64 ... 670433.28
	2 Bytes	I	C - W T U	DPT_Value_Temp	-273.00° - 670433.28°	[Cx][x] Temperature - Status	-99°C ... 199°C
	1 Byte	I	C - W T U	DPT_Value_1_Ucount	0 - 255	[Cx][x] Cost - 1-Byte Unsigned Int Status	0 ... 255
	1 Byte	I	C - W T U	DPT_Value_1_Count	-128 - 127	[Cx][x] Cost - 1-Byte Signed Int Status	-128 ... 127
	2 Bytes	I	C - W T U	DPT_Value_2_Ucount	0 - 65535	[Cx][x] Cost - 2-Byte Unsigned Int Status	0 ... 65535
	2 Bytes	I	C - W T U	DPT_Value_2_Count	-32768 - 32767	[Cx][x] Cost - 2-Byte Signed Int Status	-32768 ... 32767
	2 Bytes	I	C - W T U	9.xxx	-671088.64 - 670433.28	[Cx][x] Cost - 2-Byte Float Status	-671088.64 ... 670433.28
	1 Bit	I	C - W T U	DPT_Switch	0/1	[Cx][x] Two Objects - Switch Status	1-Bit Indicator
	1 Byte	I	C - W T U	DPT_Room_State	0 - 2	[Cx][x] Room State - Status	0 = Normal; 1 = Make Up Room; 2 = Do Not Disturb
	1 Byte	I	C - W T U	DPT_Scaling	0% - 100%	[Cx][x] Shutter - Percentage Status	0% = Top; 100% = Bottom
	1 Byte	I	C - W T U	DPT_Scaling	0% - 100%	[Cx][x] Light - Percentage Status	0% = Off; 100% = On
	2 Bytes	I	C - W T U	DPT_Value_Temp	-273.00° - 670433.28°	[Cx][x] Setpoint - Temperature Status	-99°C ... 199°C
	1 Bit	I	C - W T U	DPT_Heat_Cool	0/1	[Cx][x] Mode - Status	0 = Cool; 1 = Heat
1 Byte	I	C - W T U	DPT_HVACContrMode	0=Auto 1=Heat 3=Cool 9=Fan 14=Dry	[Cx][x] Mode - Status	Auto, Heat, Cool, Fan and Dry	
1 Byte	I	C - W T U	DPT_Scaling	0% - 100%	[Cx][x] Fan - Percentage Status	0 - 100%	

1 Byte	I	C - W T U	DPT_Fan_Stage	0 - 255	[Cx][x] Fan - Enumeration Status	Enumerated Value
1 Byte	I	C - W T U	DPT_HVACMode	1=Comfort 2=Standby 3=Economy 4=Building Protection	[Cx][x] Special Mode - Status	Auto, Comfort, Standby, Economy and Building Protection
1 Byte	I/O	CRWT U	DPT_Scaling	0% - 100%	[Cx][x] RGB - Red Channel	0% ... 100%
3 Bytes	I/O	CRWT U	DPT_Colour_RGB	[0 - 255] * 3	[Cx][x] RGB - RGB Colour	Red, Green and Blue Components
6 Bytes	I/O	CRWT U	DPT_Colour_RGBW	[0 -1] *4 - [0 - 255] * 4	[Cx][x] RGBW - RGBW Colour	Red, Green, Blue and White Components
1 Bit	I	C - W - U	DPT_Alarm	0/1	[Cx][x] Alarm - Trigger	Trigger: 0
1 Bit	I	C - W - U	DPT_Alarm	0/1	[Cx][x] Alarm - Trigger	Trigger: 1
14 Bytes	I	C - W T U	DPT_String_UTF-8		[Cx][x] Text - Status	Text String
4 Bytes	I	C - W T U	DPT_Value_4_Count	-2147483648 - 2147483647	[Cx][x] Integer - 4-Byte Signed Status	-2147483648 ... 2147483647
4 Bytes	I	C - W T U	DPT_Value_4_Ucount	0 - 4294967295	[Cx][x] Integer - 4-Byte Unsigned Status	0 ... 4294967295
4 Bytes	I	C - W T U	14.xxx		[Cx][x] Float - 4-Byte Status	-3.403E+38 ... 3.403E+38
1 Bit	I	C - W - -	DPT_Start	0/1	[Cx][x] Macro - Trigger	0 = Stop; 1 = Start
1 Bit	I	C - W - -	DPT_Start	0/1	[Cx][x] Macro - Trigger	0 = Start; 1 = Stop
1 Bit	I	C - W - -	DPT_Enable	0/1	[Cx][x] Timer - Enable	0 = Enable; 1 = Disable
1 Bit	I	C - W - -	DPT_Enable	0/1	[Cx][x] Timer - Enable	0 = Disable; 1 = Enable
1 Byte	I/O	CRWT U	DPT_Scaling	0% - 100%	[Cx][x] RGBW - Red Channel	0% ... 100%
3 Bytes	I/O	CRWT U	DPT_Colour_RGB	[0 - 255] * 3	[Cx][x] RGBW - RGB Colour	Red, Green and Blue Components
1 Bit	I	C - W T U	DPT_Switch	0/1	[Cx][x] Hold & Release - Switch Status	1-Bit Indicator
1 Byte	I	C - W T U	DPT_Value_1_Count	-128 - 127	[Cx][x] Switch - 1-Byte Signed Int Status	-128 ... 127
1 Byte	I	C - W T U	DPT_Value_1_Ucount	0 - 255	[Cx][x] Switch - 1-Byte Unsigned Int Status	0 ... 255
2 Bytes	I	C - W T U	DPT_Value_2_Count	-32768 - 32767	[Cx][x] Switch - 2-Byte Signed Int Status	-32768 ... 32767
2 Bytes	I	C - W T U	DPT_Value_2_Ucount	0 - 65535	[Cx][x] Switch - 2-Byte Unsigned Int Status	0 ... 65535
1 Byte	I	C - W T U	DPT_Scaling	0% - 100%	[Cx][x] Switch - Percentage Status	0% ... 100%

	2 Bytes	I	<b>C - W T U</b>	9.xxx	-671088.64 - 670433.28	[Cx][x] Switch - 2-Byte Float Status	-671088.64 ... 670433.28
	2 Bytes	I	<b>C - W T U</b>	DPT_Value_Temp	-273.00° - 670433.28°	[Cx][x] Switch - Temperature Status	-99°C ... 199°C
	14 Bytes	I	<b>C - W T U</b>	DPT_String_UTF-8		[Cx][x] Keypad - Status	Text String
	14 Bytes	I	<b>C - W T U</b>	DPT_String_UTF-8		[Cx][x] Multimedia - Song	Text String
	1 Bit	I	<b>C - W T U</b>	DPT_Switch	0/1	[Cx][x] Scene Selector	0 = First Scene; 1 = Second Scene
812, 818, 824, 830, 836, 842, 848, 854, 860, 866, 872, 878, 884, 890, 896, 902, 908, 914, 920, 926, 932, 938, 944, 950, 956, 962, 968, 974, 980, 986, 992, 998, 1004, 1010, 1016, 1022, 1028, 1034, 1040, 1046, 1052, 1058, 1064, 1070, 1076, 1082, 1088, 1094, 1100, 1106, 1112, 1118, 1124, 1130, 1136, 1142, 1148, 1154, 1160, 1166, 1172, 1178, 1184, 1190, 1196, 1202, 1208, 1214, 1220, 1226, 1232, 1238, 1244, 1250, 1256, 1262, 1268, 1274, 1280, 1286, 1292, 1298, 1304, 1310, 1316, 1322, 1328, 1334, 1340, 1346, 1352, 1358, 1364, 1370, 1376, 1382, 1388, 1394, 1400, 1406, 1412, 1418, 1424, 1430, 1436, 1442, 1448, 1454, 1460, 1466, 1472, 1478, 1484, 1490, 1496, 1502, 1508, 1514, 1520, 1526, 1532, 1538, 1544, 1550, 1556, 1562, 1568, 1574, 1580, 1586, 1592, 1598, 1604, 1610, 1616, 1622, 1628, 1634, 1640, 1646, 1652, 1658, 1664, 1670, 1676, 1682, 1688, 1694, 1700, 1706, 1712, 1718, 1724, 1730,	1 Bit	O	<b>C R - T -</b>	DPT_Switch	0/1	[Cx][x] Switch - Control: "0"	1-Bit Generic Control
	1 Bit	O	<b>C R - T -</b>	DPT_Switch	0/1	[Cx][x] Switch - Control: "1"	1-Bit Generic Control
	1 Bit	O	<b>C R - T -</b>	DPT_Switch	0/1	[Cx][x] Switch - Control: "0/1"	1-Bit Generic Control
	1 Bit	O	<b>C R - T -</b>	DPT_Switch	0/1	[Cx][x] Two Objects - Short Press Control: "0"	1-Bit Generic Control
	1 Bit	O	<b>C R - T -</b>	DPT_Switch	0/1	[Cx][x] Two Objects - Short Press Control: "1"	1-Bit Generic Control
	1 Bit	O	<b>C R - T -</b>	DPT_Switch	0/1	[Cx][x] Two Objects - Short Press Control: "0/1"	1-Bit Generic Control
	1 Byte	O	<b>C R - T -</b>	DPT_Value_1_Ucount	0 - 255	[Cx][x] Two Objects - Short Press Control: 1-Byte	Send Selected 1-Byte Value on Short Press
	1 Bit	O	<b>C R - T -</b>	DPT_Switch	0/1	[Cx][x] Hold & Release - Switch Control	1-Bit Generic Control
	1 Byte	O	<b>C - - T -</b>	DPT_SceneNumber	0 - 63	[Cx][x] Scene - Send Scene Control	0-63 (Run Scene 1-64)
	1 Byte	O	<b>C - - T -</b>	DPT_SceneControl	0-63; 128-191	[Cx][x] Scene - Send Scene Control	0-63/128-191 (Run/Save Scene 1-64)
	1 Byte	O	<b>C R - T -</b>	DPT_Value_1_Count	-128 - 127	[Cx][x] Integer - 1-Byte Signed Control	-128 ... 127
	1 Byte	O	<b>C R - T -</b>	DPT_Value_1_Ucount	0 - 255	[Cx][x] Integer - 1-Byte Unsigned Control	0 ... 255
	2 Bytes	O	<b>C R - T -</b>	DPT_Value_2_Count	-32768 - 32767	[Cx][x] Integer - 2-Byte Signed Control	-32768 ... 32767
	2 Bytes	O	<b>C R - T -</b>	DPT_Value_2_Ucount	0 - 65535	[Cx][x] Integer - 2-Byte Unsigned Control	0 ... 65535
	1 Byte	O	<b>C R - T -</b>	DPT_Scaling	0% - 100%	[Cx][x] Percentage - Control	0% ... 100%
	2 Bytes	O	<b>C R - T -</b>	9.xxx	-671088.64 - 670433.28	[Cx][x] Float - 2-Byte Control	-671088.64 ... 670433.28
	1 Byte	O	<b>C R - T -</b>	DPT_Room_State	0 - 2	[Cx][x] Room State - Control	0 = Normal; 1 = Make Up Room; 2 = Do Not Disturb

1736, 1742, 1748, 1754, 1760, 1766, 1772, 1778, 1784, 1790, 1796, 1802, 1808, 1814, 1820, 1826, 1832, 1838, 1844, 1850, 1856, 1862, 1868, 1874, 1880, 1886	1 Byte	O	<b>CR-T-</b>	DPT_Value_1_Ucount	0 - 255	[Cx][x] Enumeration - Control	0 ... 255
	1 Bit	O	<b>CR-T-</b>	DPT_Switch	0/1	[Cx][x] Switch - Control	1-Bit Generic Control
	1 Bit	O	<b>CR-T-</b>	DPT_Switch	0/1	[Cx][x] Two Objects - Short Press Control	1-Bit Generic Control
	1 Byte	O	<b>C--T-</b>	DPT_SceneNumber	0 - 63	[Cx][x] Two Scenes - Top Scene Send Control	0-63 (Run Scene 1-64)
	1 Byte	O	<b>C--T-</b>	DPT_SceneControl	0-63; 128-191	[Cx][x] Two Scenes - Top Scene Send Control	0-63/128-191 (Run/Save Scene 1-64)
	1 Bit	O	<b>CR-T-</b>	DPT_Step	0/1	[Cx][x] Shutter - Stop/Step Control	0 = Stop/Step Up; 1 = Stop/Step Down
	1 Bit	O	<b>CR-T-</b>	DPT_Trigger	0/1	[Cx][x] Shutter - Stop Control	0/1 = Stop
	1 Bit	O	<b>CR-T-</b>	DPT_Switch	0/1	[Cx][x] Light - Switch Control	0 = Off; 1 = On
	2 Bytes	O	<b>CR-T-</b>	DPT_Value_Temp	-273.00° - 670433.28°	[Cx][x] Setpoint - Temperature Control	-99°C ... 199°C
	1 Bit	O	<b>CR-T-</b>	DPT_Heat_Cool	0/1	[Cx][x] Mode - Control	0 = Cool; 1 = Heat
	1 Byte	O	<b>CR-T-</b>	DPT_HVACContrMode	0=Auto 1=Heat 3=Cool 9=Fan 14=Dry	[Cx][x] Mode - Control	Auto, Heat, Cool, Fan and Dry
	1 Bit	O	<b>CR-T-</b>	DPT_Step	0/1	[Cx][x] Fan - Binary Control	0 = Decrease; 1 = Increase
	1 Byte	O	<b>CR-T-</b>	DPT_Scaling	0% - 100%	[Cx][x] Fan - Percentage Control	100%
	1 Byte	O	<b>CR-T-</b>	DPT_Scaling	0% - 100%	[Cx][x] Fan - Percentage Control	50%, 100%
	1 Byte	O	<b>CR-T-</b>	DPT_Scaling	0% - 100%	[Cx][x] Fan - Percentage Control	33%, 67%, 100%
	1 Byte	O	<b>CR-T-</b>	DPT_Scaling	0% - 100%	[Cx][x] Fan - Percentage Control	25%, 50%, 75%, 100%
	1 Byte	O	<b>CR-T-</b>	DPT_Scaling	0% - 100%	[Cx][x] Fan - Percentage Control	20%, 40%, 60%, 80%, 100%
	1 Byte	O	<b>CR-T-</b>	DPT_Scaling	0% - 100%	[Cx][x] Fan - Percentage Control	0%, 100%
	1 Byte	O	<b>CR-T-</b>	DPT_Scaling	0% - 100%	[Cx][x] Fan - Percentage Control	0%, 50%, 100%
	1 Byte	O	<b>CR-T-</b>	DPT_Scaling	0% - 100%	[Cx][x] Fan - Percentage Control	0%, 33%, 67%, 100%
1 Byte	O	<b>CR-T-</b>	DPT_Scaling	0% - 100%	[Cx][x] Fan - Percentage Control	0%, 25%, 50%, 75%, 100%	

1 Byte	O	<b>CR-T-</b>	DPT_Scaling	0% - 100%	[Cx][x] Fan - Percentage Control	0%, 20%, 40%, 60%, 80%, 100%
1 Byte	O	<b>CR-T-</b>	DPT_Scaling	0% - 100%	[Cx][x] Fan - Percentage Control	Auto, 100%
1 Byte	O	<b>CR-T-</b>	DPT_Scaling	0% - 100%	[Cx][x] Fan - Percentage Control	Auto, 50%, 100%
1 Byte	O	<b>CR-T-</b>	DPT_Scaling	0% - 100%	[Cx][x] Fan - Percentage Control	Auto, 33%, 67%, 100%
1 Byte	O	<b>CR-T-</b>	DPT_Scaling	0% - 100%	[Cx][x] Fan - Percentage Control	Auto, 25%, 50%, 75%, 100%
1 Byte	O	<b>CR-T-</b>	DPT_Scaling	0% - 100%	[Cx][x] Fan - Percentage Control	Auto, 20%, 40%, 60%, 80%, 100%
1 Byte	O	<b>CR-T-</b>	DPT_Fan_Stage	0 - 255	[Cx][x] Fan - Enumeration Control	1
1 Byte	O	<b>CR-T-</b>	DPT_Fan_Stage	0 - 255	[Cx][x] Fan - Enumeration Control	1, 2
1 Byte	O	<b>CR-T-</b>	DPT_Fan_Stage	0 - 255	[Cx][x] Fan - Enumeration Control	1, 2, 3
1 Byte	O	<b>CR-T-</b>	DPT_Fan_Stage	0 - 255	[Cx][x] Fan - Enumeration Control	1, 2, 3, 4
1 Byte	O	<b>CR-T-</b>	DPT_Fan_Stage	0 - 255	[Cx][x] Fan - Enumeration Control	1, 2, 3, 4, 5
1 Byte	O	<b>CR-T-</b>	DPT_Fan_Stage	0 - 255	[Cx][x] Fan - Enumeration Control	0, 1
1 Byte	O	<b>CR-T-</b>	DPT_Fan_Stage	0 - 255	[Cx][x] Fan - Enumeration Control	0, 1, 2
1 Byte	O	<b>CR-T-</b>	DPT_Fan_Stage	0 - 255	[Cx][x] Fan - Enumeration Control	0, 1, 2, 3
1 Byte	O	<b>CR-T-</b>	DPT_Fan_Stage	0 - 255	[Cx][x] Fan - Enumeration Control	0, 1, 2, 3, 4
1 Byte	O	<b>CR-T-</b>	DPT_Fan_Stage	0 - 255	[Cx][x] Fan - Enumeration Control	0, 1, 2, 3, 4, 5
1 Byte	O	<b>CR-T-</b>	DPT_Fan_Stage	0 - 255	[Cx][x] Fan - Enumeration Control	Auto, 1
1 Byte	O	<b>CR-T-</b>	DPT_Fan_Stage	0 - 255	[Cx][x] Fan - Enumeration Control	Auto, 1, 2
1 Byte	O	<b>CR-T-</b>	DPT_Fan_Stage	0 - 255	[Cx][x] Fan - Enumeration Control	Auto, 1, 2, 3
1 Byte	O	<b>CR-T-</b>	DPT_Fan_Stage	0 - 255	[Cx][x] Fan - Enumeration Control	Auto, 1, 2, 3, 4
1 Byte	O	<b>CR-T-</b>	DPT_Fan_Stage	0 - 255	[Cx][x] Fan - Enumeration Control	Auto, 1, 2, 3, 4, 5

	1 Byte	O	<b>CR-T-</b>	DPT_HVACMode	1=Comfort 2=Standby 3=Economy 4=Building Protection	[Cx][x] Special Mode - Control	Auto, Comfort, Standby, Economy and Building Protection
	1 Bit	I	<b>C-WTU</b>	DPT_Ack	0/1	[Cx][x] Alarm - Confirmation	0 = No Action; 1 = Confirm
	1 Bit	I/O	<b>CRWTU</b>	DPT_Enable	0/1	[Cx][x] Chronothermostat - Enable	0 = Disable; 1 = Enable
	1 Bit	I/O	<b>CRWTU</b>	DPT_Enable	0/1	[Cx][x] Chronothermostat - Enable	0 = Enable; 1 = Disable
	1 Bit	O	<b>C--T-</b>	DPT_Switch	0/1	[Cx][x] Macro - Notification Control	Macro execution notification
	1 Byte	O	<b>C--T-</b>	DPT_SceneNumber	0 - 63	[Cx][x] Macro - Notification Control	Macro execution notification
	1 Byte	I/O	<b>CRWTU</b>	DPT_Scaling	0% - 100%	[Cx][x] RGBW - Green Channel	0% ... 100%
	1 Bit	O	<b>C--T-</b>	DPT_Switch	0/1	[Cx][x] Timer - Switch Control	1-Bit Generic Control
	1 Byte	O	<b>C--T-</b>	DPT_SceneNumber	0 - 63	[Cx][x] Timer - Send Scene Control	0-63 (Run Scene 1-64)
	14 Bytes	O	<b>CR-T-</b>	DPT_String_UTF-8		[Cx][x] Keypad - Control	Numerical String
	1 Byte	O	<b>C--T-</b>	DPT_SceneNumber	0 - 63	[Cx][x] First Scene - Send Scene Control	0-63 (Run Scene 1-64)
	1 Byte	O	<b>C--T-</b>	DPT_SceneControl	0-63; 128-191	[Cx][x] First Scene - Send Scene Control	0-63/128-191 (Run/Save Scene 1-64)
813, 819, 825, 831, 837, 843, 849, 855, 861, 867, 873, 879, 885, 891, 897, 903, 909, 915, 921, 927, 933, 939, 945, 951, 957, 963, 969, 975, 981, 987, 993, 999, 1005, 1011, 1017, 1023, 1029, 1035, 1041, 1047, 1053, 1059, 1065, 1071, 1077, 1083, 1089, 1095, 1101, 1107, 1113, 1119, 1125, 1131, 1137, 1143, 1149, 1155, 1161, 1167, 1173, 1179, 1185, 1191, 1197, 1203, 1209, 1215, 1221, 1227, 1233, 1239, 1245, 1251,	1 Bit	O	<b>CR-T-</b>	DPT_Switch	0/1	[Cx][x] Two Objects - Long Press Control: "0"	1-Bit Generic Control
	1 Bit	O	<b>CR-T-</b>	DPT_Switch	0/1	[Cx][x] Two Objects - Long Press Control: "1"	1-Bit Generic Control
	1 Bit	O	<b>CR-T-</b>	DPT_Switch	0/1	[Cx][x] Two Objects - Long Press Control: "0/1"	1-Bit Generic Control
	1 Byte	O	<b>CR-T-</b>	DPT_Value_1_Ucount	0 - 255	[Cx][x] Two Objects - Long Press Control: 1-Byte	Send Selected 1-Byte Value on Long Press
	1 Bit	O	<b>CR-T-</b>	DPT_Switch	0/1	[Cx][x] Two Objects - Long Press Control	1-Bit Generic Control
	1 Byte	O	<b>C--T-</b>	DPT_SceneNumber	0 - 63	[Cx][x] Two Scenes - Bottom Scene Send Control	0-63 (Run Scene 1-64)
	1 Byte	O	<b>C--T-</b>	DPT_SceneControl	0-63; 128-191	[Cx][x] Two Scenes - Bottom Scene Send Control	0-63/128-191 (Run/Save Scene 1-64)
	1 Bit	I/O	<b>CRWTU</b>	DPT_Enable	0/1	[Cx][x] Fan - Auto Mode	Switch Auto Mode on Short Press

1257, 1263, 1269, 1275, 1281, 1287, 1293, 1299, 1305, 1311, 1317, 1323, 1329, 1335, 1341, 1347, 1353, 1359, 1365, 1371, 1377, 1383, 1389, 1395, 1401, 1407, 1413, 1419, 1425, 1431, 1437, 1443, 1449, 1455, 1461, 1467, 1473, 1479, 1485, 1491, 1497, 1503, 1509, 1515, 1521, 1527, 1533, 1539, 1545, 1551, 1557, 1563, 1569, 1575, 1581, 1587, 1593, 1599, 1605, 1611, 1617, 1623, 1629, 1635, 1641, 1647, 1653, 1659, 1665, 1671, 1677, 1683, 1689, 1695, 1701, 1707, 1713, 1719, 1725, 1731, 1737, 1743, 1749, 1755, 1761, 1767, 1773, 1779, 1785, 1791, 1797, 1803, 1809, 1815, 1821, 1827, 1833, 1839, 1845, 1851, 1857, 1863, 1869, 1875, 1881, 1887	1 Bit	I/O	<b>CRWTU</b>	DPT_Enable	0/1	[Cx][x] Fan - Auto Mode	Switch Auto Mode on Long Press
	1 Byte	I/O	<b>CRWTU</b>	DPT_Scaling	0% - 100%	[Cx][x] RGB - Green Channel	0% ... 100%
	1 Bit	O	<b>CR-T-</b>	DPT_Switch	0/1	[Cx][x] Chronothermostat - On/Off Control	0 = Off; 1 = On
	1 Byte	O	<b>CR-T-</b>	DPT_Scaling	0% - 100%	[Cx][x] Light - 1-Byte Percentage Control (Only Schedulers, Macros and Voice Control)	1-Byte Dimmer Control
	1 Byte	I/O	<b>CRWTU</b>	DPT_Scaling	0% - 100%	[Cx][x] RGBW - Blue Channel	0% ... 100%
	1 Byte	O	<b>CR-T-</b>	DPT_Scaling	0% - 100%	[Cx][x] Shutter - Percentage Control	0% = Top; 100% = Bottom
	1 Byte	O	<b>CR-T-</b>	DPT_Scaling	0% - 100%	[Cx][x] Light - 1-Byte Percentage Control	1-Byte Dimmer Control
	1 Bit	I/O	<b>CRWTU</b>	DPT_Start	0/1	[Cx][x] Multimedia - Play/Pause	0 = Pause; 1 = Play
	1 Byte	O	<b>C--T-</b>	DPT_SceneNumber	0 - 63	[Cx][x] Second Scene - Send Scene Control	0-63 (Run Scene 1-64)
	1 Byte	O	<b>C--T-</b>	DPT_SceneControl	0-63; 128-191	[Cx][x] Second Scene - Send Scene Control	0-63/128-191 (Run/Save Scene 1-64)
814, 820, 826, 832, 838, 844, 850, 856, 862, 868, 874, 880, 886, 892, 898, 904, 910, 916, 922, 928, 934, 940, 946, 952, 958, 964, 970, 976, 982, 988, 994, 1000, 1006, 1012, 1018, 1024, 1030, 1036, 1042, 1048, 1054, 1060, 1066, 1072, 1078, 1084, 1090, 1096, 1102, 1108, 1114, 1120, 1126, 1132, 1138, 1144, 1150, 1156, 1162, 1168, 1174, 1180, 1186, 1192, 1198, 1204, 1210, 1216, 1222, 1228,	4 Bit	O	<b>CR-T-</b>	DPT_Control_Dimming	0x0/0x8 (Stop) 0x1...0x7 (Dec.) 0x9...0xF (Inc.)	[Cx][x] Light - 4-bits Dimming Control	4-Bit Dimming Control
	2 Bytes	I	<b>C-WTU</b>	DPT_Value_Temp	-273.00° - 670433.28°	[Cx][x] Setpoint - Ambient Temperature Status	-99°C ... 199°C
	1 Byte	I/O	<b>CRWTU</b>	DPT_Scaling	0% - 100%	[Cx][x] RGB - Blue Channel	0% ... 100%
	1 Byte	I/O	<b>CRWTU</b>	DPT_Scaling	0% - 100%	[Cx][x] RGBW - White Channel	0% ... 100%
	2 Bytes	O	<b>CR-T-</b>	DPT_Value_Temp	-273.00° - 670433.28°	[Cx][x] Chronothermostat - Setpoint Control	-99°C ... 199°C
	1 Bit	I	<b>C-WTU</b>	DPT_Switch	0/1	[Cx][x] Shutter - Move Status	0 = Stopped; 1 = Moving
	2 Bytes	I	<b>C-WTU</b>	DPT_Absolute_Colour_Temperature	0 - 65535	[Cx][x] Light - Colour Temperature Status	1000K ... 20000K

1234, 1240, 1246, 1252, 1258, 1264, 1270, 1276, 1282, 1288, 1294, 1300, 1306, 1312, 1318, 1324, 1330, 1336, 1342, 1348, 1354, 1360, 1366, 1372, 1378, 1384, 1390, 1396, 1402, 1408, 1414, 1420, 1426, 1432, 1438, 1444, 1450, 1456, 1462, 1468, 1474, 1480, 1486, 1492, 1498, 1504, 1510, 1516, 1522, 1528, 1534, 1540, 1546, 1552, 1558, 1564, 1570, 1576, 1582, 1588, 1594, 1600, 1606, 1612, 1618, 1624, 1630, 1636, 1642, 1648, 1654, 1660, 1666, 1672, 1678, 1684, 1690, 1696, 1702, 1708, 1714, 1720, 1726, 1732, 1738, 1744, 1750, 1756, 1762, 1768, 1774, 1780, 1786, 1792, 1798, 1804, 1810, 1816, 1822, 1828, 1834, 1840, 1846, 1852, 1858, 1864, 1870, 1876, 1882, 1888	1 Byte	I/O	<b>CRWT U</b>	DPT_Scaling	0% - 100%	[Cx][x] Multimedia - Volume	0% ... 100%
815, 821, 827, 833, 839, 845, 851, 857, 863, 869, 875, 881, 887, 893, 899, 905, 911, 917, 923, 929, 935, 941, 947, 953, 959, 965, 971, 977, 983, 989, 995, 1001, 1007, 1013, 1019, 1025, 1031, 1037, 1043, 1049, 1055, 1061, 1067, 1073, 1079, 1085,	1 Bit	O	<b>CR-T-</b>	DPT_UpDown	0/1	[Cx][x] Shutter - Move Control	0 = Up; 1 = Down
	2 Bytes	O	<b>CR-T-</b>	DPT_Absolute_Colour_Temperature	0 - 65535	[Cx][x] Light - Colour Temperature Control	1000K ... 20000K
	1 Bit	I	<b>C-WTU</b>	DPT_Heat_Cool	0/1	[Cx][x] Setpoint - Mode Status	0 = Cool; 1 = Heat
	1 Byte	I	<b>C-WTU</b>	DPT_Scaling	0% - 100%	[Cx][x] Shutter - Slats Status	0% = Open; 100% = Closed
	1 Bit	I/O	<b>CRWT U</b>	DPT_Enable	0/1	[Cx][x] Multimedia - Mute	0 = Disable Mute; 1 = Enable Mute

1091, 1097, 1103, 1109, 1115, 1121, 1127, 1133, 1139, 1145, 1151, 1157, 1163, 1169, 1175, 1181, 1187, 1193, 1199, 1205, 1211, 1217, 1223, 1229, 1235, 1241, 1247, 1253, 1259, 1265, 1271, 1277, 1283, 1289, 1295, 1301, 1307, 1313, 1319, 1325, 1331, 1337, 1343, 1349, 1355, 1361, 1367, 1373, 1379, 1385, 1391, 1397, 1403, 1409, 1415, 1421, 1427, 1433, 1439, 1445, 1451, 1457, 1463, 1469, 1475, 1481, 1487, 1493, 1499, 1505, 1511, 1517, 1523, 1529, 1535, 1541, 1547, 1553, 1559, 1565, 1571, 1577, 1583, 1589, 1595, 1601, 1607, 1613, 1619, 1625, 1631, 1637, 1643, 1649, 1655, 1661, 1667, 1673, 1679, 1685, 1691, 1697, 1703, 1709, 1715, 1721, 1727, 1733, 1739, 1745, 1751, 1757, 1763, 1769, 1775, 1781, 1787, 1793, 1799, 1805, 1811, 1817, 1823, 1829, 1835, 1841, 1847, 1853, 1859, 1865, 1871, 1877, 1883, 1889	1 Bit	I/O	<b>C R W T U</b>	DPT_Enable	0/1	[Cx][x] Multimedia - Mute	0 = Enable Mute; 1 = Disable Mute
816, 822, 828, 834, 840, 846, 852, 858, 864, 870, 876, 882, 888, 894, 900, 906, 912, 918, 924, 930, 936, 942, 948, 954, 960, 966, 972, 978, 984, 990	1 Bit	I/O	<b>C R W T U</b>	DPT_Switch	0/1	[Cx][x] RGBW - On/Off	0 = Off; 1 = On
	1 Bit	I/O	<b>C R W T U</b>	DPT_Switch	0/1	[Cx][x] RGB - On/Off	0 = Off; 1 = On
	1 Byte	O	<b>C R - T -</b>	DPT_Scaling	0% - 100%	[Cx][x] Shutter - Slats Control	0% = Open; 100% = Closed

996, 1002, 1008, 1014, 1020, 1026, 1032, 1038, 1044, 1050, 1056, 1062, 1068, 1074, 1080, 1086, 1092, 1098, 1104, 1110, 1116, 1122, 1128, 1134, 1140, 1146, 1152, 1158, 1164, 1170, 1176, 1182, 1188, 1194, 1200, 1206, 1212, 1218, 1224, 1230, 1236, 1242, 1248, 1254, 1260, 1266, 1272, 1278, 1284, 1290, 1296, 1302, 1308, 1314, 1320, 1326, 1332, 1338, 1344, 1350, 1356, 1362, 1368, 1374, 1380, 1386, 1392, 1398, 1404, 1410, 1416, 1422, 1428, 1434, 1440, 1446, 1452, 1458, 1464, 1470, 1476, 1482, 1488, 1494, 1500, 1506, 1512, 1518, 1524, 1530, 1536, 1542, 1548, 1554, 1560, 1566, 1572, 1578, 1584, 1590, 1596, 1602, 1608, 1614, 1620, 1626, 1632, 1638, 1644, 1650, 1656, 1662, 1668, 1674, 1680, 1686, 1692, 1698, 1704, 1710, 1716, 1722, 1728, 1734, 1740, 1746, 1752, 1758, 1764, 1770, 1776, 1782, 1788, 1794, 1800, 1806, 1812, 1818, 1824, 1830, 1836, 1842, 1848, 1854, 1860, 1866, 1872, 1878, 1884, 1890	1 Bit	O	C - - T -	DPT_Step	0/1	[Cx][x] Multimedia - Skip	0 = Backward; 1 = Forward
1891	1 Bit	O	C - - T -	DPT_Ack	0/1	[Sun] Event at Sunrise	Send 0 at Sunrise
	1 Bit	O	C - - T -	DPT_Ack	0/1	[Sun] Event at Sunrise	Send 1 at Sunrise
1892	1 Bit	O	C - - T -	DPT_Ack	0/1	[Sun] Event at Sunset	Send 0 at Sunset
	1 Bit	O	C - - T -	DPT_Ack	0/1	[Sun] Event at Sunset	Send 1 at Sunset
1893	1 Byte	O	C - - T -	DPT_SceneControl	0-63; 128-191	[Sun] Scenes: Send	0-63 (Run Scene 1-64)
1894	1 Byte	O	C - - T -	DPT_Angle	0 - 360°	[Sun] Azimuth	Current Azimuth Value [0° ... 360°]
1895	2 Bytes	O	C - - T -	DPT_Rotation_Angle	-90 - 90°	[Sun] Elevation	Current Elevation Value [-90° ... 90°]

1899	1 Bit	O	CR-T-	DPT_Trigger	0/1	[Heartbeat] Object to Send '1'	Sending of '1' Periodically
1900	1 Bit	O	CR-T-	DPT_Trigger	0/1	[Heartbeat] Device Recovery	Send 0
1901	1 Bit	O	CR-T-	DPT_Trigger	0/1	[Heartbeat] Device Recovery	Send 1
2216, 2217, 2218, 2219, 2220, 2221, 2222, 2223, 2224, 2225, 2226, 2227, 2228, 2229, 2230, 2231, 2232, 2233, 2234, 2235, 2236, 2237, 2238, 2239, 2240, 2241, 2242, 2243, 2244, 2245, 2246, 2247	1 Bit	I	C-W--	DPT_Bool	0/1	[LF] (1-Bit) Data Entry x	Binary Data Entry (0/1)
2248, 2249, 2250, 2251, 2252, 2253, 2254, 2255, 2256, 2257, 2258, 2259, 2260, 2261, 2262, 2263	1 Byte	I	C-W--	DPT_Value_1_Ucount	0 - 255	[LF] (1-Byte) Data Entry x	1-Byte Data Entry (0-255)
2264, 2265, 2266, 2267, 2268, 2269, 2270, 2271, 2272, 2273, 2274, 2275, 2276, 2277, 2278, 2279	2 Bytes	I	C-W--	DPT_Value_2_Ucount	0 - 65535	[LF] (2-Byte) Data Entry x	2-Byte Data Entry
	2 Bytes	I	C-W--	DPT_Value_2_Count	-32768 - 32767	[LF] (2-Byte) Data Entry x	2-Byte Data Entry
	2 Bytes	I	C-W--	9.xxx	-671088.64 - 670433.28	[LF] (2-Byte) Data Entry x	2-Byte Data Entry
2280, 2281, 2282, 2283, 2284, 2285, 2286, 2287	4 Bytes	I	C-W--	DPT_Value_4_Count	-2147483648 - 2147483647	[LF] (4-Byte) Data Entry x	4-Byte Data Entry
2288, 2289, 2290, 2291, 2292, 2293, 2294, 2295, 2296, 2297	1 Bit	O	CR-T-	DPT_Bool	0/1	[LF] Function x - Result	(1-Bit) Boolean
	1 Byte	O	CR-T-	DPT_Value_1_Ucount	0 - 255	[LF] Function x - Result	(1-Byte) Unsigned
	2 Bytes	O	CR-T-	DPT_Value_2_Ucount	0 - 65535	[LF] Function x - Result	(2-Byte) Unsigned
	4 Bytes	O	CR-T-	DPT_Value_4_Count	-2147483648 - 2147483647	[LF] Function x - Result	(4-Byte) Signed
	1 Byte	O	CR-T-	DPT_Scaling	0% - 100%	[LF] Function x - Result	(1-Byte) Percentage
	2 Bytes	O	CR-T-	DPT_Value_2_Count	-32768 - 32767	[LF] Function x - Result	(2-Byte) Signed
	2 Bytes	O	CR-T-	9.xxx	-671088.64 - 670433.28	[LF] Function x - Result	(2-Byte) Float



Join and send us your inquiries  
about Zennio devices:

<https://support.zennio.com>

**Zennio Avance y Tecnología S.L.**

C/ Río Jarama, 132. Nave P-8.11  
45007 Toledo, Spain.

*Tel. +34 925 232 002.*

*www.zennio.com*  
*info@zennio.com*